

Index

**RACKS**

Bun Pan Aluminum Heavy Duty End Load . . . . . 2  
 Bun Pan Aluminum Heavy Duty Side Load . . . . . 3  
 Bun Pan Aluminum & Stainless Steel Economy End Load . . . . . 4  
 Bun Pan Aluminum & Stainless Steel Economy Side Load . . . . . 5  
 Bun Pan Easy Nest Aluminum Heavy Duty End Load . . . . . 6  
 Bun Pan Aluminum & Stainless Steel Economy  
 Knockdown End Load . . . . . 7  
 Bun Pan Aluminum & Stainless Steel Economy  
 Knockdown Side Load . . . . . 8

**Sheet Pan Trucks & Dollies . . . . . 9**

**Mobile Cooling Racks . . . . . 10**

**Dunnage Racks Aluminum/Stainless Steel. . . . . 11**

**Optional Rack Accessories/Casters & Wheels. . . . . 13**

**Covers - Refrigeration, Freezer & Proofing. . . . . 16**

**Baking Pans . . . . . 18**

**Bagel Accessories . . . . . 32**

**DONUT FILLERS & ACCESSORIES**

Power Base . . . . . 34  
 Filler Units . . . . . 36  
 Spouts . . . . . 38  
 Filler Accessories . . . . . 40

**Lug Carts / Ingredient Bins . . . . . 45**

**Mixers . . . . . 46**

**Humidifiers . . . . . 47**

**Ovens/Convection . . . . . 48**

**Divider Rounders . . . . . 49**

**Appendix A . . . . . 50**

**Appendix B . . . . . 52**

**Appendix C - Special Fabrications . . . . . 55**

Photographs and product illustrations in this catalog may differ from actual product.

Product specifications are subject to change without notice.

The use of any trademark within this document is solely intended to provide assistance or information for people who use these products. Ineqco Intl LLC disclaims any proprietary intent in trademarks and trade names other than their own.

**1-877-363-6662**

**Price Changes:**

In the event of market Fluctuations, our prices are subject to change without notice

## Bun Pan Racks/Heavy Duty

Bun Pan Racks  
 Aluminum  
 HEAVY DUTY  
 End Load



ITEM# 4205

### Plate Casters

Item #	Capacity	Spacing	Price	Weight
4205	30	2"	\$225.56	58
4612	20	3"	\$186.30	47
4615	15	4"	\$175.76	42
4619	12	5"	\$166.37	39
4623	10	6"	\$160.13	37

\*\* Overall dimensions: 70"h x 20.5"w x 26"d\*\*

2026	27	2"	\$211.11	51
2027	18	3"	\$177.97	42
2028	14	4"	\$170.56	41
2029	11	5"	\$161.19	37
2030	9	6"	\$154.96	35

\*\* Overall dimensions: 65"h x 20.5"w x 26"d\*\*

### Stem Casters

Item #	Capacity	Spacing	Price	Weight
4000	30	2"	\$218.91	56
4610	20	3"	\$171.62	45
4613	15	4"	\$166.14	39
4617	12	5"	\$156.78	36
4621	10	6"	\$150.54	34

\*\* Overall dimensions: 70"h x 20.5"w x 26"d\*\*

1813	27	2"	\$209.29	51
1277	18	3"	\$163.50	42
1814	14	4"	\$161.14	38
1815	11	5"	\$151.79	35
1816	9	6"	\$145.55	33

\*\* Overall dimensions: 65"h x 20.5"w x 26"d\*\*

## Bun Pan Racks/Heavy Duty

Bun Pan Racks  
 Aluminum  
 HEAVY DUTY  
 Side Load



ITEM# 4158

### Plate Casters

Item #	Capacity	Spacing	Price	Weight
4609	30	2"	\$207.07	49
4611	20	3"	\$173.01	42
4616	15	4"	\$170.08	38
4620	12	5"	\$163.66	36
4624	10	6"	\$156.84	35

\*\* Overall dimensions: 70"h x 28.5"w x 26"d\*\*

2031	27	2"	\$198.78	46
2032	18	3"	\$166.86	40
2033	14	4"	\$165.89	37
2034	11	5"	\$159.46	35
2035	9	6"	\$152.65	34

\*\* Overall dimensions: 65"h x 28.5"w x 26"d\*\*

### Stem Casters

Item #	Capacity	Spacing	Price	Weight
4570	30	2"	\$188.57	46
4158	20	3"	\$167.17	39
4614	15	4"	\$156.46	35
4618	12	5"	\$150.04	33
4622	10	6"	\$143.23	32

\*\* Overall dimensions: 70"h x 28.5"w x 26"d\*\*

1817	27	2"	\$187.87	43
1818	18	3"	\$155.95	37
1819	14	4"	\$147.39	34
1820	11	5"	\$140.97	32
1821	9	6"	\$134.16	31

\*\* Overall dimensions: 65"h x 28.5"w x 26"d\*\*

**We accept Visa, Mastercard,  
 American Express, and Discover**

**Price Changes:**

In the event of market Fluctuations, our prices are subject to change without notice

## Bun Pan Racks

Bun Pan Racks  
Aluminum  
& Stainless Steel  
End Load



ITEM# 4205E

### Plate Casters

Item #	SS	Pan Cap.	Runner Space	Price AL	SS	Weight AL /SS
4205E	6065E	30	2"	\$190.54 /	\$327.45	47 /95
4612E	6064E	20	3"	\$160.04 /	\$255.33	39 /73
4615E	6063E	15	4"	\$152.38 /	\$229.71	35 /61
4619E	6062E	12	5"	\$144.74 /	\$205.70	32 /55
4623E	6061E	10	6"	\$139.66 /	\$175.15	31 /50

\*\* Overall dimensions: 70"h x 20.5"w x 26"d\*\*

2026E	6060E	27	2"	\$181.20 /	\$310.45	44 /87
2027E	6059E	18	3"	\$153.24 /	\$243.17	37 /67
2028E	6058E	14	4"	\$148.13 /	\$222.38	33 /58
2029E	6057E	11	5"	\$144.25 /	\$198.37	31 /51
2030E	6056E	9	6"	\$135.40 /	\$183.44	29 /47

\*\* Overall dimensions: 65"h x 20.5"w x 26"d\*\*

### Stem Casters

Item #	SS	Pan Cap.	Runner Space	Price AL	SS	Weight AL /SS
4000E	6050E	30	2"	\$188.94 /	\$325.00	41 /89
4610E	6049E	20	3"	\$158.43 /	\$252.88	34 /67
4613E	6048E	15	4"	\$150.77 /	\$227.26	30 /56
4617E	6047E	12	5"	\$143.14 /	\$203.25	27 /49
4621E	6046E	10	6"	\$138.05 /	\$189.53	26 /44

\*\* Overall dimensions: 70"h x 20.5"w x 26"d\*\*

1813E	6045E	27	2"	\$179.60 /	\$307.99	39 /81
1277E	6044E	18	3"	\$151.64 /	\$240.71	32 /61
1814E	6043E	14	4"	\$149.05 /	\$219.93	28 /52
1815E	6042E	11	5"	\$141.42 /	\$195.92	26 /46
1816E	6041E	9	6"	\$136.33 /	\$180.52	24 /41

\*\* Overall dimensions: 65"h x 20.5"w x 26"d\*\*

**Price Changes:**

In the event of market Fluctuations, our prices are subject to change without notice

## Bun Pan Racks

Bun Pan Rack  
Aluminum  
& Stainless Steel  
Side Load



ITEM# 4158E

### Plate Casters

Item #	SS	Pan Cap.	Runner Space	Price AL	SS	Weight AL /SS
4609E	7322E	30	2"	\$182.42 /	\$289.37	41 /76
4611E	7323E	20	3"	\$153.51 /	\$237.37	36 /61
4616E	7324E	15	4"	\$144.68 /	\$216.11	33 /53
4620E	7325E	12	5"	\$134.11 /	\$196.71	31 /48
4624E	7326E	10	6"	\$125.22 /	\$182.04	30 /45

\*\* Overall dimensions: 70"h x 28.5"w x 18"d\*\*

2031E	7327E	27	2"	\$173.19 /	\$276.97	39 /70
2032E	7328E	18	3"	\$151.11 /	\$228.27	34 /57
2033E	7329E	14	4"	\$145.54 /	\$210.32	32 /50
2034E	7330E	11	5"	\$140.32 /	\$190.93	30 /44
2035E	7331E	9	6"	\$134.32 /	\$176.25	29 /43

\*\* Overall dimensions: 65"h x 28.5"w x 18"d\*\*

### Stem Casters

Item #	SS	Pan Cap.	Runner Space	Price AL	SS	Weight AL /SS
4570E	7337E	30	2"	\$174.74 /	\$286.92	36 /70
4158E	7338E	20	3"	\$145.80 /	\$234.92	31 /55
4614E	7339E	15	4"	\$131.67 /	\$213.66	28 /47
4618E	7340E	12	5"	\$123.27 /	\$194.27	26 /43
4622E	7341E	10	6"	\$117.01 /	\$179.59	25 /39

\*\* Overall dimensions: 70"h x 28.5"w x 18"d\*\*

1817E	7332E	27	2"	\$166.96 /	\$274.52	34 /64
1818E	7333E	18	3"	\$141.10 /	\$225.82	29 /51
1819E	7334E	14	4"	\$130.22 /	\$207.87	27 /45
1820E	7335E	11	5"	\$121.80 /	\$188.47	25 /40
1821E	7336E	9	6"	\$115.74 /	\$173.81	24 /37

\*\* Overall dimensions: 65"h x 28.5"w x 18"d\*\*

# 1-877-363-6662

## Bun Pan Racks/Easy Nest

Bun Pan Racks  
 Easy Nest  
 Aluminum  
 & Stainless Steel  
 End Load & Side Load

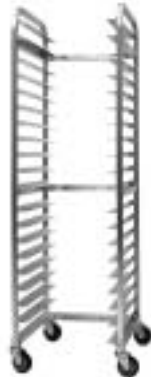

ITEM# 6139E

### Stem Casters - End Load

Item #	AL	SS	Pan Cap.	Runner Space	Price AL	Price SS	Weight AL/SS
6140E	6010E	30	2"	\$230.36 / \$377.40	56 /121		
6139E	6009E	20	3"	\$206.55 / \$320.16	46 /97		
6138E	6008E	15	4"	\$200.71 / \$286.76	41 /85		
6137E	6007E	12	5"	\$197.82 / \$262.94	38 /78		
6136E	6006E	10	6"	\$194.88 / \$243.89	36 /73		

\*\* Overall dimensions: 70"h x 20.5"w x 26"d\*\*

6135E	6005E	27	2"	\$219.80 / \$360.49	52 /113	
6134E	6004E	18	3"	\$198.97 / \$307.98	43 /92	
6133E	6003E	14	4"	\$196.13 / \$279.37	39 /82	
6132E	6002E	11	5"	\$193.24 / \$255.55	36 /75	
6131E	6121E	9	6"	\$190.29 / \$236.50	34 /71	

\*\* Overall dimensions: 65"h x 20.5"w x 26"d\*\*

### Stem Casters - Side Load

Item #	AL	SS	Pan Cap.	Runner Space	Price AL	Price SS	Weight AL/SS
7521E	8281E	30	2"	\$199.71 / \$403.45	52 /96		
7520E	8282E	20	3"	\$188.31 / \$362.10	45 /80		
7519E	8283E	15	4"	\$184.13 / \$336.68	42 /72		
7518E	8284E	12	5"	\$176.91 / \$317.63	40 /65		
7517E	8285E	10	6"	\$179.94 / \$301.77	38 /64		

\*\* Overall dimensions: 70"h x 20.5"w x 26"d\*\*

7530E	8276E	27	2"	\$191.94 / \$391.28	50 /93	
7529E	8277E	18	3"	\$182.59 / \$353.11	43 /76	
7528E	8278E	14	4"	\$180.46 / \$330.87	41 /70	
7527E	8279E	11	5"	\$177.34 / \$311.83	38 /65	
7526E	8280E	9	6"	\$176.28 / \$295.97	37 /62	

\*\* Overall dimensions: 65"h x 20.5"w x 26"d\*\*

**Price Changes:**

In the event of market Fluctuations, our prices are subject to change without notice

## Bun Pan Racks/Knock Down

Bun Pan Racks  
 Knock Down  
 Aluminum  
 & Stainless Steel  
 End Load



ITEM# 4610KD

### Plate Casters

Item #	AL	SS	Pan Cap.	Runner Space	Price AL	Price SS	Weight AL/SS
4205KD	6065KD	30	2"	\$186.25 / \$301.21	49 /105		
4612KD	6064KD	20	3"	\$158.03 / \$230.99	40 /82		
4615KD	6063KD	15	4"	\$143.92 / \$206.79	36 /71		
4619KD	6062KD	12	5"	\$135.58 / \$187.12	34 /64		
4623KD	6061KD	10	6"	\$129.81 / \$184.53	32 /60		

\*\* Overall dimensions: 70"h x 20.5"w x 26"d\*\*

2026KD	6060KD	27	2"	\$176.20 / \$284.21	49 /97	
2027KD	6059KD	18	3"	\$150.28 / \$218.22	40 /77	
2028KD	6058KD	14	4"	\$139.64 / \$199.46	36 /68	
2029KD	6057KD	11	5"	\$131.30 / \$184.47	34 /61	
2030KD	6056KD	9	6"	\$125.53 / \$179.42	32 /57	

\*\* Overall dimensions: 65"h x 20.5"w x 26"d\*\*

### Stem Casters

Item #	AL	SS	Pan Cap.	Runner Space	Price AL	Price SS	Weight AL/SS
4000KD	6050KD	30	2"	\$175.77 / \$297.64	43 /98		
4610KD	6049KD	20	3"	\$147.55 / \$227.42	42 /76		
4613KD	6048KD	15	4"	\$133.44 / \$203.22	31 /65		
4617KD	6047KD	12	5"	\$125.10 / \$183.58	28 /58		
4621KD	6046KD	10	6"	\$119.33 / \$180.55	27 /53		

\*\* Overall dimensions: 70"h x 20.5"w x 26"d\*\*

1813KD	6045KD	27	2"	\$165.73 / \$280.63	40 /90	
1277KD	6044KD	18	3"	\$140.07 / \$215.25	33 /70	
1814KD	6043KD	14	4"	\$129.16 / \$195.89	29 /61	
1815KD	6042KD	11	5"	\$120.82 / \$180.83	27 /55	
1816KD	6041KD	9	6"	\$115.05 / \$175.36	25 /50	

\*\* Overall dimensions: 65"h x 20.5"w x 26"d\*\*

# 1-877-363-6662

## Bun Pan Racks/Knock Down

Bun Pan Racks  
 Knock Down  
 Aluminum  
 & Stainless Steel  
 Side Load



ITEM# 4158KD

### Plate Casters

Item #	AL	SS	Pan Cap.	Runner Space	Price		Weight
					AL	SS	
4609KD		7322KD	30	2"	\$179.71/	\$246.94	50 /85
4611KD		7323KD	20	3"	\$152.13 /	\$210.28	42 /69
4616KD		7324KD	15	4"	\$143.66 /	\$193.77	38 /62
4620KD		7325KD	12	5"	\$133.60 /	\$176.55	35 /57
4624KD		7326KD	10	6"	\$125.11 /	\$162.73	34 /54

\*\* Overall dimensions: 70"h x 28.5"w x 18"d\*\*

2031KD		7327KD	27	2"	\$168.94 /	\$252.54	50 /79
2032KD		7328KD	18	3"	\$144.77 /	\$201.18	42 /65
2033KD		7329KD	14	4"	\$136.58 /	\$187.97	38 /59
2034KD		7330KD	11	5"	\$125.24 /	\$170.76	34 /55
2035KD		7331KD	9	6"	\$120.60 /	\$156.94	33 /52

\*\* Overall dimensions: 65"h x 28.5"w x 18"d\*\*

### Stem Casters

Item #	AL	SS	Pan Cap.	Runner Space	Price		Weight
					AL	SS	
4570KD		7337KD	30	2"	\$158.45 /	\$261.36	44 /78
4158KD		7338KD	20	3"	\$144.23 /	\$206.70	36 /63
4614KD		7339KD	15	4"	\$130.48 /	\$190.19	34 /55
4618KD		7340KD	12	5"	\$122.74 /	\$172.98	32 /51
4622KD		7341KD	10	6"	\$117.24 /	\$159.16	30 /48

\*\* Overall dimensions: 70"h x 28.5"w x 18"d\*\*

1817KD		7332KD	27	2"	\$151.53 /	\$248.96	41 /73
1818KD		7333KD	18	3"	\$134.13 /	\$197.61	34 /59
1819KD		7334KD	14	4"	\$125.77 /	\$184.40	31 /53
1820KD		7335KD	11	5"	\$119.93 /	\$167.18	28 /48
1821KD		7336KD	9	6"	\$115.82 /	\$153.37	27 /45

\*\* Overall dimensions: 65"h x 28.5"w x 18"d\*\*

#### Price Changes:

In the event of market Fluctuations, our prices are subject to change without notice

## Trucks and Dollies

### Bun Pan Dolly

Aluminum and Stainless Steel  
 Heavy Duty  
 Sanitary All-Welded Assembly  
 5" Swivel Plate Casters  
 100 Pan Capacity 18" x 26"



Item #	Description	Price	Wgt
7729	19"w x 27"d x 7"h	\$103.75	22
7729S	19"w x 27"d x 7"h	\$134.44	30

### Sheet Pan Truck

Aluminum and Stainless Steel  
 Heavy Duty 3 Side w/ Reinforced  
 Handle for Easy Maneuvering  
 Sanitary All Welded Assembly  
 5" Swivel Plate Casters  
 100 Pan Capacity 18 x 26



Item #	Description	Price	Wgt
10496	21.5"w x 28.5"d x 28"h	\$152.26	29
10496S	21.5"w x 28.5"d x 28"h	\$208.11	48

### Sheet Pan Truck

Aluminum and Stainless Steel  
 Heavy Duty 4 Side w/ Reinforced  
 Handle for Easy Maneuvering  
 Sanitary All Welded Assembly  
 5" Swivel Plate Casters  
 100 Pan Capacity 18 x 26



Item #	Description	Price	Wgt
MI10497	21.5"w x 28.5"d x 28"h	\$156.20	29
MI10497S	21.5"w x 28.5"d x 28"h	\$216.39	51

### Sheet Pan Truck

Aluminum and Stainless Steel  
 Heavy Duty All Welded Assembly  
 5" Swivel Plate Casters  
 100 Pan Capacity 18 x 26



Item #	Description	Price	Wgt
10495	19"w x 27"d x 40.5"h	\$132.90	27
10495S	19"w x 27"d x 40.5"h	\$183.98	39

## Trucks and Cooling Racks



ITEM #10495SDBL  
ITEM #10495DBL



ITEM #2083T  
ITEM #10497T  
ITEM #10497THD



ITEM #6628T  
ITEM #10496T  
ITEM #10496THD



ITEM #2251

Stainless Steel Tubular Construction /5" Plate Casters  
Sanitary All-Welded Construction

Item #	Description	Price	Wgt
6628T	21.5"w x 27"d x 47.5"h	\$236.14	48
2083T	21.5"w x 28"d x 33.5"h	\$237.58	51
10495SDBL	40"w x 28.5"d x 33.5"h	\$258.92	98

Heavy Duty Aluminum Tubular Construction /5" Plate Casters  
Sanitary All-Welded Construction

Item #	Description	Price	Wgt
2251	19.5"w x 27.5"d x 47"h	\$210.39	24
10496T	21.5"w x 28.5"d x 47.5"h	\$139.45	29
10496THD	22"w x 29"d x 47.5"h	\$172.93	34
10497T	21.5"w x 28.5"d x 33.5"h	\$131.89	29
10497THD	22"w x 29"d x 33.5"h	\$161.94	52.5
10495DBL	40"w x 28.5"d x 33.5"h	\$185.66	33

## Mobile Cooling Racks

Cooling, Storing, Transporting  
Merchandising  
Baked Goods  
Aluminum  
Standard 1" Tube  
5" Stem Casters



Item #	Description	Price	Wgt
9026	25"w (635mm)x49"d (1245mm)x 68"h(1727mm) - 11"spacing	\$679.77	203
9026-1	25"w (635mm)x72"d (1829mm)x 68"h (1727mm) - 11"spacing	\$998.85	294

10

## Dunnage Racks



Dunnage Racks  
Heavy Duty/Durable

Aluminum Tubular  
*\*Also Available in Stainless Steel*

1-3/4" x 1-1/2" Frame Tubing

Item #	Overall Dimensions			Cpty	Wgt	Price
	Width	Length	Height			
RDTA203612	20	36	12	1500	15	\$ 66.52
RDTA204812	20	48	12	1800	17	\$ 72.59
RDTA206012	20	60	12	2000	19	\$ 78.65
RDTA243612	24	36	12	1500	15	\$ 67.53
RDTA244812	24	48	12	1800	17	\$ 73.60
RDTA246012	24	60	12	2000	19	\$ 79.66
RDTA203608	20	36	8	1500	14	\$ 64.50
RDTA204808	20	48	8	1800	16	\$ 70.57
RDTA206008	20	60	8	2000	18	\$ 76.63
RDTA243608	24	36	8	1500	15	\$ 62.52
RDTA244808	24	48	8	1800	17	\$ 71.58
RDTA246008	24	60	8	2000	19	\$ 78.65

## Dunnage Racks

Heavy Duty/Durable

Aluminum Tubular  
with Gusset Legs

*\*Also Available in Stainless Steel*

1-1/2" Frame Tubing



Item #	Overall Dimensions			Cpty.	Wgt	Price
	Width	Length	Height			
RDGA203612	20	36	12	1500	15	\$ 84.92
RDGA204812	20	48	12	1800	17	\$ 90.99
RDGA206012	20	60	12	2000	19	\$ 97.05
RDGA243612	24	36	12	1500	15	\$ 85.93
RDGA244812	24	48	12	1800	17	\$ 91.99
RDGA246012	24	60	12	2000	19	\$ 98.06

# 1-877-363-6662

11

## Dunnage Racks

### Dunnage Racks

Heavy Duty/Durable

Aluminum Tubular

with Channel

*\*Also Available in Stainless Steel*

1-3/4" x 1-1/2" Tubular Frame

with 4" x 1-1/2" Channel



Item #	Overall Dimensions			Cpty.	Wgt	Price
	Width	Length	Height			
RDCA203612	20	36	12	1500	20	\$ 77.65
RDCA204812	20	48	12	1800	23	\$ 87.17
RDCA206012	20	60	12	2000	26	\$ 96.69
RDCA243612	24	36	12	1500	20	\$ 78.66
RDCA244812	24	48	12	1800	23	\$ 88.18
RDCA246012	24	60	12	2000	27	\$ 97.70
RDCA203608	20	36	8	1500	19	\$ 75.63
RDCA204808	20	48	8	1800	22	\$ 85.15
RDCA206008	20	60	8	2000	26	\$ 94.67
RDCA243608	24	36	8	1500	19	\$ 76.64
RDCA244808	24	48	8	1800	23	\$ 86.16
RDCA246008	24	60	8	2000	26	\$ 95.68

### Dunnage Racks

Heavy Duty/Durable

Stainless Steel



Item #	Overall Dimensions			Cpty.	Wgt	Price
	Width	Length	Height			
RDTS203612	20	36	12	1500	29	\$148.24
RDTS204812	20	48	12	1800	34	\$165.14
RDTS206012	20	60	12	2000	39	\$182.04
RDTS243612	24	36	12	1500	29	\$151.06
RDTS244812	24	48	12	1800	35	\$167.96
RDTS246012	24	60	12	2000	40	\$184.86
RDTS203608	20	36	8	1500	22	\$147.98
RDTS204808	20	48	8	1800	27	\$164.82
RDTS206008	20	60	8	2000	32	\$181.75
RDTS243608	24	36	8	1500	23	\$150.75
RDTS244808	24	48	8	1800	28	\$167.35
RDTS246008	24	60	8	2000	33	\$184.38

## Optional Rack Accessories/Casters & Wheels



### Optional Rack Accessories

Item #	Description	Price	Wgt
1061	PAN STOP Aluminum	\$15.97	1.67
1824	X-BRACE Aluminum	\$22.03	2.41
7343	PAN STOP Stainless Steel	\$28.96	2.79
1823	X-BRACE Stainless Steel	\$44.93	4.53

### Casters & Wheels

7409	STEM CASTER 6"h w/5"h Polyolefin Wheel	\$ 6.36	1.5
9021	STEM CASTER .84 5"h w/4"h Polyurethane Wheel	\$12.02	2.65
9021-LT	STEM CASTER 5"h w/4"h Polyurethane Wheel Low Temperature - 30F	\$17.62	2.65
5040	STEM CASTER 5"h w/4"h Rigid Polyurethane Wheel w/Ball Bearing	\$24.37	2.5
1322	STEM CASTER 6"h w/5"h Rubber Wheel w/Brake	\$16.87	2
4206	PLATE CASTER 5"h W/4"h Phenolic Wheel w/Bushing	\$14.01	2.5
2208	PLATE CASTER 6.25"h w/5"h Polyurethane Wheel 300# Ball Bearing	\$12.27	3
5106	PLATE CASTER 6.25"h w/5"h Black Phenolic Wheel 300#	\$16.98	3
6283	PLATE CASTER 6.25"h w/5"h Black Phenolic Wheel 300# Bushing w/Built-In Zerk Grease Fitting	\$25.65	5

\* You can find reference material in Appendix B



Optional Rack Accessories/Casters & Wheels



Options And Accessories

Item #	Description	Price	Wgt
2467	PLATE CASTER 7.5"h w/4"h Black Phonelic Wheel 550# Roller Bearing w/Built-In Zerk Grease Fitting	\$ 36.76	7
5108	PLATE CASTER 5"h w/4"h Grooved Steel Wheel 600# Roller Bearing w/Built-In Zerk Grease Fitting	\$ 57.63	6.1
6570	PLATE CASTER 5.6h w/4"h Black Phonelic Wheel 700# Roller Bearing w/Built-In Zerk Grease Fitting	\$ 25.96	7.5
1450	PLATE CASTER 6.5"h w/5"h Polyolefin Wheel 800# Ball Bearing w/Built-In Zerk Grease Fitting	\$ 25.63	7
2310	PLATE CASTER 5"h w/4"H Polyolefin Wheel 475F High Temperature Bushing w/Built-In Zerk Grease Fitting	\$ 15.43	2.45
2219	PLATE CASTER 5"h Stainless Steel w/4"h Black Phonelic Wheel 300F High Temperature Bushing w/Built- In Zerk Grease Fitting	\$ 45.16	2.5
2155	PLATE CASTER 5"h w/4"h Steel Wheel 525F High Temperature Bushing w/Built-In Zerk Grease Fitting	\$ 18.72	5.5
6851	PLATE CASTER 5"h w/4"h Polyolefin Wheel 525F High Temperature Bushing w/Built-In Zerk Grease Fitting Donut Style	\$ 13.79	2.25
1266	PLATE CASTER 5"h w/4"h Polyurethane Wheel 250# Ball Bearing	\$ 11.39	2.5
1266E	PLATE CASTER Economy 5"h w/4"h Polyurethane Wheel 250# Ball Bearing	\$ 8.73	2.5
1266-LT	PLATE CASTER 5"h w/4" Polyurethane Wheel Low Temperature 250# Ball Bearing	\$ 20.62	2.5
5098	BRAKE Assembly for Caster #1266	\$ 5.74	0.22

\* You can find reference material in Appendix B

Optional Rack Accessories/Casters & Wheels



Options And Accessories

Item #	Description	Price	Wgt
5091	PLATE CASTER 5"h w/4"h Polyurethane Wheel 250# Ball Bearing	\$ 15.81	2.5
1699	AXLE Assembly for #4206, #6851 & #2310	\$ 3.14	0.1
1698	NUT Assembly for #4206, #6851 & #2310	\$ 0.47	0.1
1700	BUSHING Assembly for #4206, #6851 & #2310	\$ 1.49	0.1
6847	WHEEL High Temperature Black Polyolefin 4" Diameter	\$ 7.16	1.0
1068	WHEEL High Temperature Brown Phenolic 4" Diameter	\$ 9.31	1.0
1067	WHEEL Semi-Steel 4" Diameter	\$ 12.90	3.0
8374	WHEEL High Temperature Black Polyolefin 3" Diameter	\$ 10.25	1.0
7140	WHEEL High Temperature Brown Phenolic 3" Diameter	\$ 10.25	1.0
7270	GREASE High Temperature	\$ 8.40	1.0
7793	GREASE Low Temperature	\$ 12.80	1.0
8039	GUN Grease Gun - Lever Type	\$ 41.34	1.0
8546	NEEDLE Injector for Gun	\$ 6.40	0.1

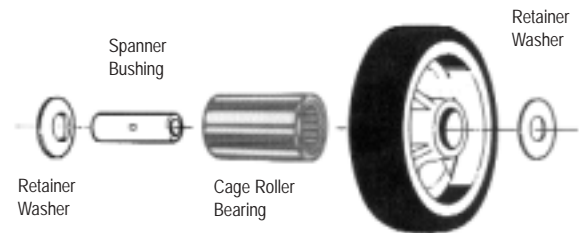

\* You can find reference material in Appendix B



Covers

Covers



**"CLEAR" Cover**  
 Heavy duty double polished clear vinyl. New rugged reinforced top panel to prevent ripping.



**"FREEZER" Cover**  
 3-ply reinforced flame retardant material.

Item #	Description	Price	Wgt
1411	23"x 28"x 64"h, w/zipper	\$ 48.00	5
1411E	ECONOMY 23"x 28"x64"h w/zipper	\$ 33.00	5
5258	23"x 28"x60"h, w/zipper	\$ 56.10	5
1411E-1	ECONOMY 23"x 28"x60"h w/zipper	\$ 33.00	5

Item #	Description	Price	Wgt
1410	23"x 28"x 64"h, w/zipper & Window Front	\$ 92.98	5
1410-1	23"x 28"x 60"h, w/zipper & Window Front	\$ 92.98	5

**"HERCULES" Cover**  
 Our most rugged , durable cover. Tough, reinforced flame retardant material.



Item #	Description	Price	Wgt
5054	23"x 28"x64"h, w/Velcro & Window Front	\$ 88.00	6
5054-Z	23"x 28"x64"h, w/zipper & Window Front	\$ 88.00	6
5089	23"x 28"x60"h, w/Velcro & Window Front	\$ 88.00	6
5054-E	ECONOMY 23"x 28"x60"h, w/zipper & Window Front	\$ 53.90	6

**"3 ZIPPER CLEAR" Cover**  
 Heavy duty, durable vinyl cover with reinforced plastic viewing panel. 3 zippers allow for use with both End and Side Loading Racks.



Item #	Description	Price	Wgt
17766	64"h, w/zipper	\$ 82.00	5

## Bread Pans

**Single Open Top Bread Pans** - 26 gauge aluminized steel  
1/4 " Wire in Rim



Item #	Top In	Bottom Out	Depth	Weight Each	Approx. Loaf Wgt
13010*	5 5/8 x 3 1/8	5 x 2 1/2	2 3/16	.4	3/8 lb
13020+	5 5/8 x 3 1/8	5 x 2 1/2	2 1/4	.4	3/8 lb
13030	7 3/8 x 3 5/8	6 3/4 x 3	2 1/4	.8	5/8 lb
13040	8 x 4	7 1/4 x 3 1/4	2 1/4	.9	3/4 lb
13050	8 1/2 x 4 1/2	7 5/8 x 3 5/8	2 3/4	1.0	1 lb
13060	9 x 4 1/2	8 1/4 x 3 3/4	2 3/4	1.0	1 lb
13070	10 x 5	9 3/8 x 4 3/8	3	1.3	1 1/2 lb
13080	12 1/4 x 4 1/2	11 1/2 x 3 3/4	2 3/4	1.3	1 1/2 lb
13090**	7 1/4 x 3 5/8	6 3/4 x 3	2 1/4	.8	1/2 lb

+ Seamless Construction Style, Curled Rim, No Wire

\*\* Large Bottom Radius Balled Corners

## Strapped Bread Pans

**3-Strap Open Top Bread Pans** - aluminized steel  
1-5/8 " Band Over Wire - 18 gauge



Individual Pan Size

Item #	Top In	Bottom Out	Depth	Weight Per Set	Overall Size
13210	8 1/2 x 4 1/2	7 5/8 x 3 5/8	2 3/4	4.3	9 7/32 x 17 27/32
13220	9 x 4 1/2	8 1/4 x 3 3/4	2 3/4	4.5	9 23/32 x 17 3/4
13230	10 x 5	9 3/8 x 4 3/8	3	5.6	10 23/32 x 18
13240	12 1/4 x 4 1/2	11 1/2 x 3 3/4	2 3/4	5.9	12 31/32 x 17 3/4

Item #	Price
13010	\$3.00
13020	\$5.76
13030	\$6.00
13040	\$6.30
13050	\$6.18

Item #	Price
13060	\$6.48
13070	\$6.54
13080	\$6.54
13090	\$6.72

Item #	Price
13210	\$20.18
13220	\$20.24
13230	\$22.95
13240	\$22.72

## Strapped Bread Pans

**Strapped Bread Pans**  
**4-Strap Open Top Bread Pans** - aluminized steel  
1-5/8 " Band Over Wire - 18 gauge



Individual Pan Size

Item #	Top In	Bottom Out	Depth	Weight Per Set	Overall Size
13310*	5 5/8 x 3 1/8	5 x 2 1/2	2 3/16	1.6	6 1/8 x 17 7/8
13320	8 x 4	7 1/4 x 3 1/4	2 1/2	5.2	8 11/16 x 19 3/4
13330	8 1/2 x 4 1/2	7 5/8 x 3 5/8	2 3/4	5.5	9 7/32 x 21 7/8
13340	8 1/2 x 5 3/4	8 x 5	3	6.9	9 3/16 x 26
13350	9 x 4 1/2	8 1/4 x 3 3/4	2 3/4	5.8	9 23/32 x 21 7/8
13360	10 x 5	9 3/8 x 4 3/8	3	6.7	10 23/32 x 23 7/8
13370	10 x 5	9 3/8 x 4 3/8	3	7.4	10 23/32 x 26
13380	12 x 5	11 1/4 x 4 1/4	3 1/2	8.6	12 11/16 x 23 3/8
13390	12 1/4 x 4 1/2	11 1/2 x 3 3/4	2 3/4	7.3	12 31/32 x 21 7/8
13392	10 x 5	9 1/2 x 4 1/2	3 1/4	7.4	10 3/4 x 25 7/8

\* 1 x tin-coated steel

## Strapped Bread Pans

**5-Strap Open Top Bread Pan Sets** - aluminized steel  
1-5/8 " Band Over Wire - 18 gauge



Individual Pan Size

Item #	Top In	Bottom Out	Depth	Weight Per Set	Overall Size
13510	7 3/8 x 3 5/8	6 3/4 x 3	2 1/4	5.5	8 1/16 x 25 3/4
13520	8 1/2 x 4 1/2	7 5/8 x 3 5/8	2 3/4	6.7	9 7/32 x 26
13530	9 x 4 1/2	8 1/4 x 3 3/4	2 3/4	7.0	9 23/32 x 26
13540	12 1/4 x 4 1/2	11 1/2 x 3 3/4	2 3/4	9.0	12 31/32 x 26

Item #	Price
13310	\$11.76
13320	\$22.14
13330	\$22.39
13340	\$31.46
13350	\$23.65

Item #	Price
13360	\$24.86
13370	\$25.03
13380	\$26.07
13390	\$26.18
13392	\$26.18

Item #	Price
13510	\$31.52
13520	\$29.04
13530	\$29.15
13540	\$30.36

## Strapped And Folded Bread Pans

### Strapped Bread Pans

**6-Strap Open Top Bread Pan Sets** - aluminized steel  
1-5/8" Band Over Wire - 18 gauge



Individual Pan Size

Item #	Top In	Bottom Out	Depth	Weight Per Set	Overall Size
13610+	5 5/8 x 3 1/8	5 x 2 1/2	2 1/4	3.4	6 x 25 7/8
13620*	5 5/8 x 3 1/8	5 x 2 1/2	2 3/16	2.4	6 1/8 x 25 7/8

+ Individual Pans Have a Seamless Construction Style, Curled Rim, No Wire  
\* 1 x tin-coated steel

### Folded End Pullman Pans

**Single Pullman Pans** - 26 gauge aluminized steel  
1/4" Wire in Rim



Individual Pan Size

Item #	Top In	Bottom Out	Depth	Weight Each	Approx. Loaf Wgt
13710	13 x 4	12 3/4 x 3 3/4	4	1.7	1 1/2 lb
13720		Sliding Cover		.5	-----
13730	16 x 4	15 3/4 x 3 3/4	4	2.1	2 lb
13740		Sliding Cover		.6	-----

Item #	Price
13610	\$25.63
13620	\$14.15

Item #	Price
13710	\$10.20
13720	\$ 9.00
13730	\$11.10
13740	\$ 9.30

## Folded End Pullman Pans

**3-Strap Pullman Pans** - aluminized steel  
1-5/8" Band Over Wire - 18 gauge

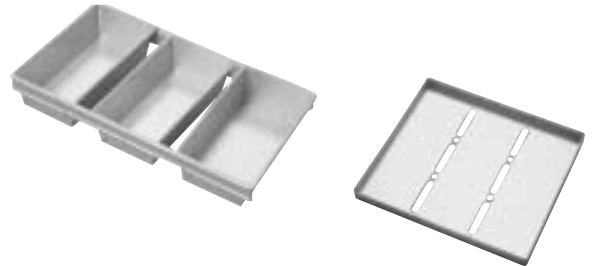

Individual Pan Size

Item #	Top In	Bottom Out	Depth	Weight Per Set	Overall Size
13810	13 x 4*	12 3/4 x 3 3/4	4	6.8	13 23/32 x 15 5/8
13820		Drop Cover		4.5	14 3/8 x 16 9/32
13830	16 x 4**	15 3/4 x 3 3/4	4	7.8	16 23/32 x 15 3/4
13840		Drop Cover		5.3	17 3/8 x 16 13/32

\*1 1/2 lb loaf  
\*\* 2 lb loaf

**4-Strap Pullman Pans** - aluminized steel  
1-5/8" Band Over Wire - 18 gauge



Individual Pan Size

Item #	Top In	Bottom Out	Depth	Weight Per Set	Overall Size
13850	13 x 4*	12 3/4 x 3 3/4	4	9.0	13 3/4 x 21 3/8
13860		Drop Cover		6.0	14 3/4 x 22 3/8

\* 1 1/2 lb loaf

Item #	Price
13810	\$36.58
13820	\$23.16
13830	\$37.95
13840	\$25.63

Item #	Price
13850	\$44.33
13860	\$53.90

Special Pans

**Special Pans**

**Hearth Bread Pan Sets** - 22 gauge aluminized steel  
loaf weight 2 lb.  
1-5/8 " Band Over Wire - 18 gauge

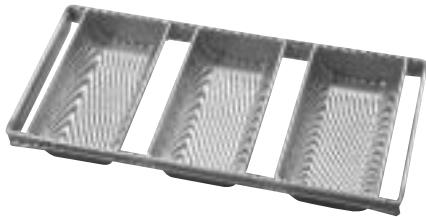

Individual Pan Size

Item #	Top In	Bottom Out	Depth	Weight Per Set	Overall Size
3 pans per set, with bottom and sidewall perforations					
14010	11 1/2 x 6	11 x 3 1/2	2 1/2	6.5	12 3/16 x 25 7/8
4 pans per set, with quilted bottom and UTI holes only					
14020	11 1/2 x 5 3/4	11 x 3 7/8	2 3/4	7.6	12 3/16 x 26

**Crimped Round Bread Pan Set** - 4 pans per set - 26 gauge aluminized steel  
approximate loaf weight 1 lb.  
1-5/8 " Band Over Wire - 18 gauge



Individual Pan Size

Item #	Length	Diameter	Weight Per Set	Overall Size
14110	10	3 3/4	9.7	10 9/16 x 18 3/8
14120 *	11 1/64	3 5/8		
14130 *	10 15/64	3 15/16		
14140 *	15 3/4	1 25/32		

\* Choose arrangement

Item #	Price
14010	\$44.33
14020	\$45.49

Item #	Price
14110	\$61.16
14120	\$61.16
14130	\$61.00
14140	\$86.63

Special Pans

**Special Pans**

**Cinnamon/Package Roll Pan Set** - 3 pans per set aluminized steel  
1-5/8 " Band Over Wire



Individual Pan Size

Item #	Top In	Bottom Out	Depth	Weight Per Set	Overall Size
14220	9 1/4 x 6 5/8	9 x 6 3/8	1 7/8	4.5	9 7/8 x 22 1/8
14250	10 x 6 3/8	9 27/32 x 6 7/64	1 7/8		
14300	9 5/16 x 6 5/8	8 7/8 x 6 1/16	1 7/8	4.5	10 1/16 x 22 7/8

\* Choose arrangement

**Breadstick Pan** - 14 gauge aluminum



Item #	Grooves	Groove Width	Weight Each	Overall Size
14590	14	9/16	3.5	17 7/8 x 25 7/8

Item #	Price	Item #	Price
14220	\$33.11	14590	\$29.65
14250	\$41.64		
14300	\$43.54		

**1-877-363-6662**

## Baguette Pans

### Baguette Pans

#### Baguette / French Bread Pans

16 gauge perforated aluminum - 0.081" diameter



Item #	Molds Per Pan	Mold Dimensions	Weight Each	Overall Size
*11410FS	4 long	3 7/8 x 25 3/4	2.8	17 3/4 x 25 3/4 x 1
*11420FS	5 long	3 x 25 3/4	2.9	17 3/4 x 25 3/4 x 1
*11430FS	5 across	3 7/8 x 17 3/4	3.1	17 3/4 x 25 3/4 x 1
*11440FS	6 long	2 13/32 x 25 3/4	3.1	17 3/4 x 25 3/4 x 1
*11450FS	3 long	5 x 25 3/4	3.3	17 3/4 x 25 3/4 x 2
11410	4 long	3 7/8 x 25 3/4	3.7	17 3/4 x 25 3/4 x 1
11420	5 long	3 x 25 3/4	3.5	17 3/4 x 25 3/4 x 1
11430	5 across	3 7/8 x 17 3/4	3.9	17 3/4 x 25 3/4 x 1
11440	6 long	2 13/32 x 25 3/4	3.9	17 3/4 x 25 3/4 x 1
11450	3 long	5 x 25 3/4	4.4	17 3/4 x 25 3/4 x 2

\* Food Service Grade

### Baguette Frames and sub/sandwich pans

#### French Bread Pans With Reinforcing Frame

22 gauge perforated aluminum

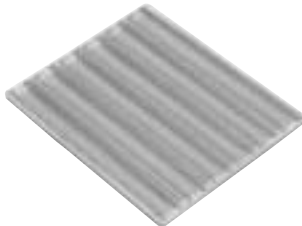

Item #	Molds Per Pan	Mold Dimensions	Weight Each	Overall Size
14410	4 long	3 7/8 x 25 1/4	2.8	17 7/8 x 25 7/8 x 1 1/8
14420	5 long	3 x 25 1/4	2.9	17 7/8 x 25 7/8 x 1 1/8
14430	5 across	3 7/8 x 17 1/4	3.1	17 7/8 x 25 7/8 x 1 1/8
14440	6 long	2 13/32 x 25 1/4	3.1	17 7/8 x 25 7/8 x 1 1/8
14450	3 long	5 x 25 1/4	2.9	17 7/8 x 25 7/8 x 1 1/8

OBS: 1) Can be used in automatic lines  
2) Can be fitted with accessory for stacking

Item #	Price	Item #	Price	Item #	Price
11410FS	\$17.71	11410	\$30.80	14410	\$23.41
11420FS	\$17.71	11420	\$30.80	14420	\$23.41
11430FS	\$17.71	11430	\$30.80	14430	\$23.41
11440FS	\$17.71	11440	\$30.80	14440	\$23.41
11450FS	\$17.71	11450	\$30.80	14450	\$23.41

## Sub-Sandwich and Bun Pans

### Sub-Sandwich Roll Pans

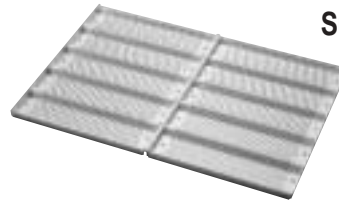

#### Mold Dimensions

Item #	Top In	Bottom Out	Top Width	Depth	Weight Each	Overall Size
Full-sized with 10 individual 12 1/2 x 3" flat-bottomed molds, each with endcaps						
14310	12 1/2	2 3/8	3	23/32	4.1	18 x 25 5/16 x 1
Half-sized with 5 individual 12 1/2 x 3" flat-bottomed molds, each with endcaps						
14320	12 1/4	2 3/8	3	23/32	1.9	18 x 13 x 1
Half-sized with 5 individual 12 1/4" x 2 3/4" half-round molds, no endcaps						
14330	12 1/4	1/2 rnd	2 3/4	25/32	1.6	17 3/8 x 13 x 1 1/8

### Bun Pans

#### Hamburger Bun Pans / Muffin Top Pans

22 gauge aluminized steel - seamless construction

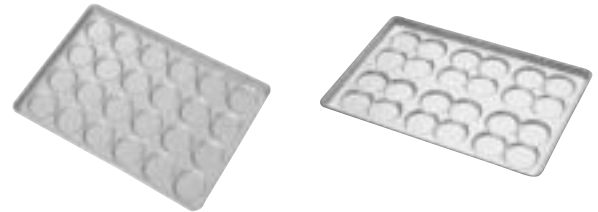

Item #	Top In	Bottom Out	Vert. Depth	Arragt.	Weight Each	Overall Size
Individual hamburger buns/rolls and muffin tops						
14610 **	3 3/4	3 1/16	13/32	4 x 6	5.9	17 11/16 x 25 11/16 x 1 1/8
14620 **	4 1/4	3 5/8	1/2	4 x 6	6.6	19 1/2 x 28 3/4 x 1 1/8
14630 **	4 1/8	3 7/8	1/2	3 x 5	5.4	17 11/16 x 25 11/16 x 1 1/8
14640+	3 5/8	3 3/8	9/16	4 x 6	7.9	17 3/4 x 25 3/4 x 1 1/8
14650 *	3 5/8	3 3/8	9/16	4 x 6	8.2	17 3/4 x 25 3/4 x 1 1/8
14660+	4 1/8	3 3/4	1/2	3 x 5	7.4	17 3/4 x 25 3/4 x 1 1/8
14670+ **	4 1/8	3 7/8	1 1/8	2 x 3	5.4	12 x 17 5/8
14680+	5	4 3/4	1/2	3 x 4	7.4	17 3/4 x 25 3/4 x 1 1/8
Clustered hamburger buns/rolls - 4 buns/rolls per cluster						
14700 +	3 3/4	3 3/8	1/2	2 x 3	6.0	17 11/16 x 25 11/16 x 1 1/8
* 1/4" Diameter Wire in Rim + 1/2" Band in Rim ** Molds Seamed ++ 26 gauge						

Item #	Price	Item #	Price	Item #	Price
14310	\$49.83	14620	\$18.40	14660	\$21.16
14320	\$29.37	14630	\$19.72	14670	\$18.51
14330	\$24.26	14640	\$20.47	14680	\$21.85
14610	\$18.40	14650	\$19.78	14700	\$20.30

## Bun And Muffin Pans

## Muffin Pans

### Bun Pans

**Hot Dog Bun Pans** - 26 gauge aluminized steel -seamless construction, 1/4" Diameter Wire in Rim



Item #	Top In	Bottom Out	Vert. Depth	Arragt.	Weight Each	Overall Size
Individual hot-dogs buns/rolls						
14810	6 x 2 1/16	5 1/2 x 1 9/16	1/2	4 x 6	5.7	16 3/4 x 27 3/4 x 1
14820	6 x 2 1/16	5 1/2 x 1 9/16	1/2	3 x 6	5.9	17 11/16 x 25 11/16 x 1 1/8
14830	6 x 1 7/8	5 11/16 x 1 5/8	1/2	3 x 6	5.9	17 3/4 x 25 3/4 x 1 1/8
14840	6 x 1 7/8	5 11/16 x 1 5/8	1/2	4 x 6	5.7	16 3/4 x 27 3/4 x 1 1/8
14850*	7 7/8 x 2 1/2	7 5/16 x 2 1/8	7/16	2 x 6	5.7	17 3/4 x 25 3/4 x 1 1/8
14860	10 x 2 1/8	9 1/2 x 1 5/8	3/8	2 x 6	5.5	17 3/4 x 25 3/4 x 1 1/8
Clustered hot-dog buns/rolls - 4 buns/rolls per cluster						
14880	6 x 2 1/16	5 9/16 x 1 9/16	17/32	2 x 4	6.7	19 1/2 x 28 3/4 x 1 1/8
14890*	12 x 2 3/4	11 3/4 x 2 7/16	3/8	1 x 2	8	17 3/4 x 25 3/4 x 1 1/8

\* 1/2" Flat Band in Rim

### Muffin Pans

**Oversized muffin pans**  
5/16" Diameter Wire in Rim,  
cookie sheet style  
22 gauge aluminized steel



Item #	Arrgt.	Vol.	Top In	Bottom Out	Vert. Depth	L	W	Wgt.	Overall Size
Large Muffin									
15310	3 x 4	5.0	3 1/4	2 1/2	1 1/4	3 5/8	3 5/8	3.5	12 7/8 x 17 7/8
15312	4 x 6	5.0	3 1/4	2 1/2	1 1/4	3 5/8	3 5/8	6.4	17 7/8 x 25 7/8
Texas - Size									
15320	3 x 4	5.6	3 3/16	2 15/16	1 1/4	3 5/8	3 5/8	3.9	12 7/8 x 17 7/8
15322	4 x 6	5.6	3 3/16	2 15/16	1 1/4	3 5/8	3 5/8	7.1	17 7/8 x 25 7/8
Jumbo Muffin									
15330	3 x 4	6.2	3 1/2	3 1/32	1 1/4	4 1/8	4 1/8	3.7	13 1/8 x 17 7/8
15332	4 x 5	6.2	3 1/2	3 1/32	1 1/4	4 1/8	4 1/8	6.6	17 7/8 x 25 7/8
15334	3 x 4	7.0	3 3/8	3	1 1/2	4	3 15/16	4.1	12 7/8 x 17 7/8
15336	4 x 6	7.0	3 3/8	3	1 1/2	3 7/8	4	7.1	17 7/8 x 25 7/8
15338	4 x 6	7.0	3 3/8	2 15/16	1 17/32	4	4	7.6	17 7/8 x 25 3/4

We report the liquid volume if filled to brim - use 60-70% for batter weight

Item #	Price	Item #	Price	Item #	Price
14810	\$18.40	14880	\$19.21	15322	\$45.54
14820	\$19.84	14890	\$22.95	15330	\$25.58
14830	\$20.24	15310	\$25.08	15332	\$44.44
14840	\$18.81	15312	\$43.45	15334	\$25.36
14850	\$22.95	15320	\$25.25	15336	\$45.60
14860	\$21.28			15338	\$45.43

### Muffin Pans

**Mini-muffin and Cupcake Frames**  
5/16" Diameter Wire in Rim,  
cookie sheet style  
22 gauge aluminized steel



Item #	Arrgt.	Vol.	Top In	Bottom Out	Vert. Depth	L	W	Wgt.	Overall Size
Mini-Muffin Pans - Aluminized Steel									
15110	4 x 6	1.1	2 1/16	1 5/8	1 1/16	2 1/2	2 1/2	1.3	11 1/8 x 15 3/4
15120	5 x 6	1.1	1 7/8	1 1/4	7/8	2 3/4	2 1/4	3.8	12 7/8 x 17 7/8
15130	6 x 8	1.1	1 7/8	1 1/4	7/8	2 3/4	2 1/4	6.8	17 7/8 x 25 7/8
15140+	4 x 6	2.1	2 1/16	1 5/8	1 1/8	2 3/4	2 3/4	3.7	12 7/8 x 17 7/8
15150	6 x 8	2.1	2 1/16	1 5/8	1 1/8	2 3/4	2 3/4	7.1	17 7/8 x 25 7/8
Cupcake / Muffin Pans - Aluminized Steel									
15210	3 x 4	3.8	2 3/4	2 1/16	1 3/8	3 5/16	3 5/16	1.8	10 5/8 x 13 7/8
15220	3 x 4	3.8	2 3/4	2 1/16	1 3/8	4	4	3.3	12 7/8 x 17 7/8
15230+	4 x 6	3.8	2 3/4	2 1/16	1 3/8	3 5/16	3 5/16	4.4	14 1/16 x 20 11/16
15240	5 x 7	3.8	2 3/4	2 1/16	1 3/8	3 5/16	3 5/16	6.3	17 7/8 x 25 7/8
15250	4 x 6	3.8	2 3/4	2 1/16	1 3/8	4	4	6.1	17 7/8 x 25 7/8
15260	5 x 7	3.8	2 3/4	2 1/16	1 3/8	3 9/32	3 5/16	6.3	17 7/8 x 25 7/8
Aluminum Muffin Pan									
15410	3 x 4	3.8	2 3/4	2 1/16	1 3/8	3 5/16	3 5/16	2.0	10 3/4 x 14 1/8
15420	4 x 6	3.8	2 3/4	2 1/16	1 3/8	3 5/16	3 5/16	3.2	20 3/4 x 14 1/8

We report the liquid volume if filled to brim - use 60-70% for batter weight

\*\* No Wire in Rim

+ 26 gauge

Item #	Price	Item #	Price	Item #	Price
15110	\$16.33	15210	\$12.60	15240	\$38.78
15120	\$47.03	15220	\$14.21	15250	\$38.34
15130	\$52.42	15230	\$18.81	15260	\$43.67
15140	\$20.70			15410	\$28.99
15150	\$51.76			15420	\$38.17

# 1-877-363-6662

Muffin Pans

**Muffin Pans**

**Large muffin pans**

5/16" Diameter Wire in Rim, cookie sheet style  
22 gauge aluminized steel

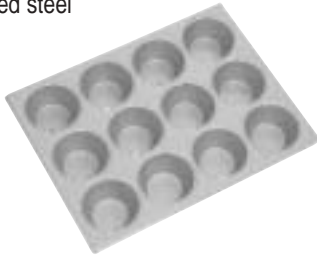

Item #	Arrgt.	Vol.	Top In	Bottom Out	Vert. Depth	L	W	Wgt.	Overall Size
<b>Large - Crown</b>									
15340	3 x 4	7.3	3 1/2	2 1/16	1 15/16	4 1/8	4 1/8	3.8	13 1/8 x 17 7/8
15342	4 x 5	7.3	3 1/2	2 1/16	1 15/16	4 1/8	4 1/8	6.8	17 7/8 x 25 7/8
15344	3 x 5	7.5	4 1/8	2 1/16	1 15/16	4 5/8	4 5/8	8.0	17 3/4 x 25 3/4
<b>Pecan - Roll</b>									
15350	3 x 4	8.2	3 11/16	2 1/2	1 13/16	4 1/4	4 1/4	3.9	13 1/2 x 17 7/8
15352	4 x 5	8.2	3 11/16	2 1/2	1 13/16	4 1/4	4 1/4	6.4	17 7/8 x 25 7/8
<b>Mini - Cake</b>									
15360	3 x 4	10.5	4 1/4	3 3/4	1 1/2	4 7/8	4 7/8	4.9	15 1/2 x 20 1/2
15362	3 x 5	10.5	4 1/4	3 3/4	1 1/2	4 21/32	4 7/8	6.6	17 7/8 x 25 7/8

We report the liquid volume if filled to brim - use 60-70% for batter weight

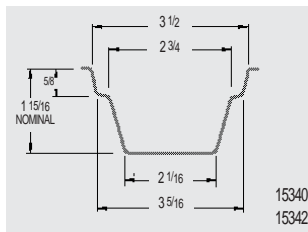
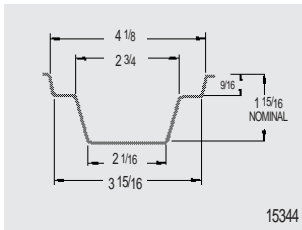

Item #	Price
15340	\$30.75
15342	\$47.96
15344	\$39.66
15350	\$27.94

Item #	Price
15352	\$48.79
15360	\$29.04
15362	\$51.76

Muffin - Specialty Pans

**Muffin Pans - Specialty Pans**

5/16" Diameter Wire in Rim, cookie sheet style  
22 gauge aluminized steel



Item #	Arrgt.	Vol.	Top In	Bottom Out	Vert. Depth	L	W	Wgt.	Overall Size
<b>Mary Ann / Strawberry Shortcake</b>									
15510+	3 x 4	6.0	3 3/8	3	1 1/2	4	3 15/16	3.8	12 7/8 x 17 7/8
15520+	4 x 6	6.0	3 3/8	3	1 1/2	3 13/16	3 13/16	7.3	17 7/8 x 25 7/8
<b>Mini Loaf</b>									
15610	2 x 6	6.4	3 7/8 x 2 1/2	3 1/2 x 2 1/8	1 5/16	3 1/8	4 1/2	3.6	9 7/8 x 19 1/2
15620	4 x 7	6.4	3 7/8 x 2 1/2	3 1/2 x 2 1/8	1 5/16	3 1/8	4 1/2	7.9	18 7/8 x 25 7/8
15630	3 x 8	6.4	3 7/8 x 2 1/2	3 1/2 x 2 1/8	1 5/16	3 1/8	4 1/2	7.9	17 7/8 x 25 7/8
<b>Square Muffin</b>									
15710*	3 x 4	4.4	2 5/8 x 2 5/8	2 x 2	1 9/16	3 1/4	3 1/8	2.1	10 3/4 x 14 1/8
15720*	4 x 6	4.4	2 5/8 x 2 5/8	2 x 2	1 9/16	3 1/8	3 1/4	3.5	14 1/8 x 20 3/4
15730+	3 x 4	4.4	2 3/4 x 2 3/4	2 1/4 x 2 1/4	1 1/4	3 1/4	3 1/4	3.5	10 3/4 x 14

We report the liquid volume if filled to brim - use 60-70% for batter weight

+ 26 gauge aluminized steel

\* aluminum

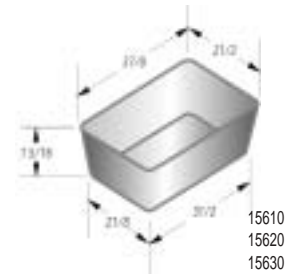
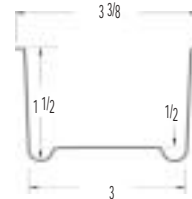
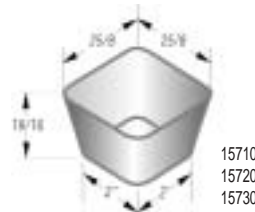

Item #	Price
15510	\$25.03
15520	\$44.77
15610	\$24.59
15620	\$58.74

Item #	Price
15630	\$40.04
15710	\$52.09
15720	\$52.09
15730	\$16.22



## Full Size Sheet Pans

## Half Size - Specialty Sheet Pans

### Full Size Sheet Pans

### Half Size and Special Sheet Pans

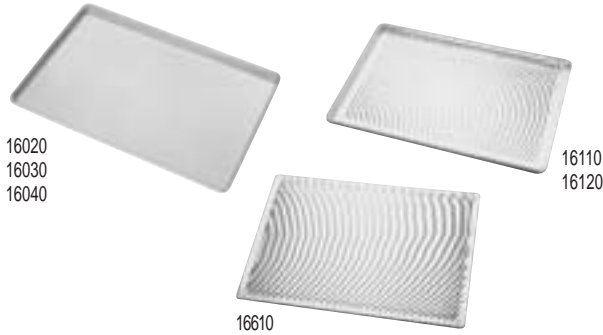

Item #	Material Thickness	Weight Each	Overall Size
<b>Aluminum</b>			
16010*	12 gauge	4.0	18 x 26 x 1
16020	16 gauge, BISSC+ approved	4.0	18 x 26 x 1
16030	18 gauge, BISSC+ approved	3.4	18 x 26 x 1
16040	20 gauge, BISSC+ approved	2.9	18 x 26 x 1
<b>Perforated Aluminum</b>			
16110	16 gauge - bottom perf. only	3.3	18 x 26 x 1
16120	18 gauge - bottom perf. only	2.9	18 x 26 x 1
16130	16 gauge - perf. All over	2.9	18 x 26 x 1
<b>Hard Coat Anodized Aluminum</b>			
16210	16 gauge Bākalon	3.1	18 x 26 x 1
<b>Aluminized Steel</b>			
16220	23 gauge aluminized steel	5.8	18 x 26 x 1
16222	22 gauge alzd, band in rim	6.1	17 3/4 x 25 3/4
<b>Perforated Aluminized Steel</b>			
16230	23 gauge - sq. perf. all over	4.4	18 x 26 x 1
<b>Bagel and Swedish Style Perforated Screens</b>			
16510++	14 gauge - .094 dia. Perf.	2.2	18 x 26
16520++	12 gauge - .081 dia Perf.	2.9	18 x 26
16530+++	14 gauge - .081 dia Perf.	2.9	18 x 26
<b>Perforated Screen - Cookie Sheet Style Wire in Rim</b>			
16610**	16 gauge - bottom perf. only	3.7	18 x 26

Item #	Material Thickness	Weight Each	Overall Size
<b>Aluminum</b>			
16310	18 gauge	2.1	18 x 13 x 1
16320*	14 gauge	1.6	18 x 13 x 1
<b>Hard Coat Anodized Aluminum</b>			
16330*	14 gauge	1.6	18 x 13 x 1
<b>Aluminized Steel</b>			
16340	26 gauge	2.6	18 x 13 x 1
<b>Perforated Aluminum</b>			
16350	18 gauge - bottom perf. only	1.9	18 x 13 x 1
<b>Tin-Coated Steel Sheet / Jelly Roll Pan</b>			
16360	4 x tinplate	1.6	18 x 12 x 1
<b>Display Pans - gold anodized aluminum - semi-curved rim</b>			
16410	16 gauge	2.4	18 x 26 x 1
16420	16 gauge	1.2	9 x 26 x 1
16430	16 gauge	1.1	12 x 18 x 1

\* Sanitary Open Bead

Item #	Price	Item #	Price	Item #	Price
16310	\$ 5.25	16340	\$ 7.28	16410	\$22.22
16320	\$ 8.48	16350	\$ 9.60	16420	\$17.47
16330	\$14.52	16360	\$11.88	16430	\$16.47

- \* Sanitary Open Bead
- \*\* Wire in Rim style - Cookie Sheet style
- + Baking Industry Sanitation Comitee
- ++ Ends turned up
- +++ Sides turned up

Item #	Price	Item #	Price	Item #	Price
16010	\$14.68	16120	\$11.10	16230	\$22.66
16020	\$ 8.19	16130	\$20.43	16510	\$21.00
16030	\$ 6.70	16210	\$21.37	16520	\$21.65
16040	\$ 6.70	16220	\$16.91	16530	\$19.83
16110	\$15.25	16222	\$19.55	16610	\$19.97

**Price Changes:**  
In the event of market Fluctuations, our prices are subject to change without notice

# 1-877-363-6662

Bagel Accessories

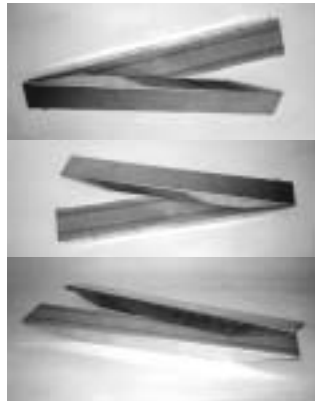

Bagel Accessories

Item #	Description	Price	Wgt
6755	Basket Chrome 14"x 20"x 6"	\$ 24.73	4.00
6757	Basket Chrome 7"x 20"x 6"	\$ 38.50	3.00
6758	Basket Chrome 21"x 20"x 6"	\$ 48.50	7.00
6756	Basket Chrome 18"x 24"x 8"	\$ 40.15	7.00
8495	Divider for Basket, Chrome 14"x 20"	\$ 17.60	1.00
5099	Scoop Chrome	\$ 33.28	4.00
6335	Oven Peel Wood 24"x 24"x 30" w/Wood Handle	\$ 43.04	11.00
6329	Oven Peel Aluminum 24"x 24"x 30" w/Wood Handle	\$ 88.80	11.00
6329-LT	Aluminum 24"x 24"x 30" w/Wood Handle *New Design	\$101.50	11.00
7218-WH	Handle Replacement w/Hardware for #6335, #6329 & #6329-LT	\$ 24.14	2.00
5093	Proofing Board 18"x 26" Wood	\$ 6.74	4.00
6767	Proofing Board 18"x 26" Plastic	\$ 9.90	4.00
7674	Proofing Board 18"x 26" Molded Fiberglass	\$ 14.64	5.00
5221	Oven Brush - 51"L	\$ 25.20	3.00
5221-S	Oven Brush - 51"L w/Scrapper	\$ 42.00	4.00
6771	Stirrer Stainless Steel	\$ 86.55	4.00
6330	Stirrer Wood	\$ 12.82	2.00
6763	Baking Board 2"x 4"x 25" Redwood w/Burlap	\$ 10.79	3.00

Price Changes:

In the event of market Fluctuations, our prices are subject to change without notice

Bagel Accessories

Item #	Description	Price	Wgt
5273	Baking Board 2"x 4"x 25" Aluminum w/Burlap	\$ 21.83	3.0
6177	Baking Board 2"x 4"x 25" Aluminum	\$ 15.24	
6178	Clips - Stainless Steel	\$ 4.11	
7411	Baking Board 2"x 4"x 25" Redwood w/Teflon	\$ 37.54	0.1
7412	Baking Board 2"x 4"x 25" Aluminum w/Teflon	\$ 48.83	3.0
7364	Baking Board 2"x 4"x 25" Redwood w/Cotton	\$ 27.13	3.0
8091	Baking Board 2"x 4"x 25" Aluminum w/Cotton	\$ 33.20	3.0
8074	Baking Board 2"x 4"x 25 Aluminum w/ Cotton Clipless *New Design	\$ 37.05	3.0
8089	Baking Board 2"x 4"x 25" Aluminum w/Teflon Clipless *New Design	\$ 40.95	3.0
8090	Baking Board 2"x 4"x 25" Aluminum w/ Burlap Clipless *New Design	\$ 16.19	3.0
8075	Baking Board Only, Clipless, Aluminum 2"x 4"x 25"	\$ 13.75	2.0
6768	Aluminum Baking Board 2"x 4"x 25" Redwood, No Cover	\$ 7.69	2.0
5135-Roll	Roll Burlap 3 5/8"x 72yds	\$ 57.15	11.0
7706-Roll	Roll Teflon	\$260.70	4.0
7737-Roll	Roll Cotton Webbing	\$162.00	7.0
6972	Strips Teflon	\$ 23.25	1.0
7780	Wizard w/Free Liner Gloves	\$ 20.21	1.0
6777	Replacement Hook	\$ 7.29	0.1
6800	Stainless Steel Nails	\$ 0.12	0.005



Power Base

Filler Unit

**Fill Donuts, Eclairs, Munchkins, Cupcakes, Cream Puffs and Such**

**Power Base**

The Power Base is a totally enclosed, self-contained Volumetric metering Device, extremely functional and easy to clean. The latest solid state technology insures reliability and ease of operation; thereby increasing productivity and profit, while enhancing appearance, and assuring uniformity of the finished product.

Amount to be dispensed is easily entered into the system's memory via the digital Entry Keypad, thus insuring accuracy and eliminating waste. Maximum amount dispensed is 16 or 32 ounces per cycle. At the end of each metering cycle the pump reverses to eliminate dripping.

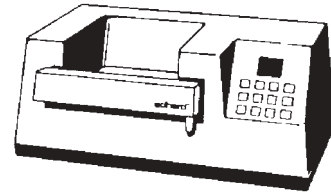

Item #	Description	Price	Wgt
Power Base			
3020	# P-4010 120V, 60Hz, 1/25HP	\$1150.80	12
3021	# P-4012 120V, 60Hz, 1/15HP	\$1400.70	12
3025	# P-4020 220/240V, 50Hz, 1/17HP	\$1505.70	12

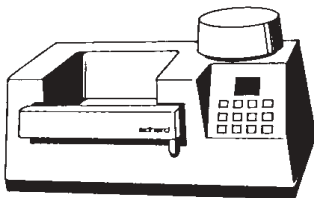

Item #	Description	Price	Wgt
Power Base			
3001	# PS-4028 120V, 60Hz, 1/8HP	\$1968.75	18
3003	# PS-4030 220/240V, 50Hz, 1/8HP	\$1968.75	18
Power Base Variable Speed			
3010	# PV-4000 120V, 50/60Hz, 1/4HP,	\$3041.85	18
3011	# PV-4001 220/240V, 50/60Hz, 1/4HP	\$3041.85	18

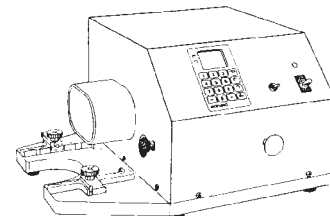

Item #	Description	Price	Wgt
Power Base Transfer			
3030	# PT-4035 100/120V, 50/60Hz, 1/3HP	\$4836.30	30
3031	# PT-4036 200/240V, 50/60Hz, 1/3HP	\$4836.30	30

**Price Changes:**

In the event of market Fluctuations, our prices are subject to change without notice

**1-877-363-6662**

Filler Units

Filler Units

**Filler Units**

These units are self-contained Metering Pumps and product containers complete with lid and interchangeable stainless steel spouts.

Double Spout Filler Units are used to fill donuts, eclairs, munchkins, cupcakes, cream puffs, and such with jam, jelly, custard and other fillings, two at a time.

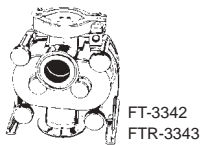

FT-3342  
FTR-3343

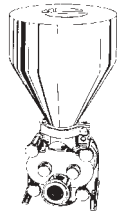

FT-5027  
FT-5029  
FT-5032  
FT-5033  
FT-5028  
FT-5030  
FT-5034  
FT-5035

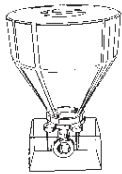

FHP-5025  
FHP-5026  
FHP-5031

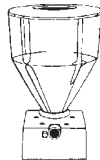

F-5003

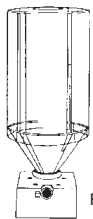

F-5007

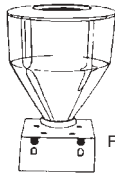

F-5001

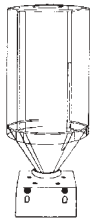

F-5005

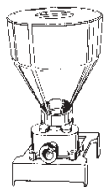

RP-5018  
RP-5012

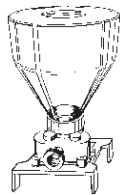

FS-5009  
FS-5010

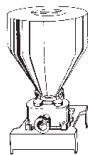

RP-5019  
RP-5013  
RP-5023  
RP-5022  
RP-5024

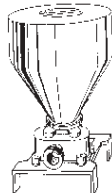

FS-5008  
FS-5011  
FS-5020  
FS-5021  
FS-5036

Item #	Description	Price	Wgt
Pump Assembly, St. Steel Single Outlet Vertical			
3100	# FT-3342 - Gear Type	\$1601.25	20
3101	# FTR-3343 - Lobe Type	\$2021.25	20

Filler Unit, St. Steel Single Output Gear Type			
3110	# FT-5027 - 18Qt. (17 l.)	\$2462.25	21
3111	# FT-5029 - 18Qt. (17 l.) w/Pressure Disc	\$2677.50	21
3112	# FT-5032 - 36Qt. (32 l.)	\$3055.50	27
3113	# FT-5033 - 36Qt. (32 l.) w/Pressure Disc	\$3255.00	27

Filler Unit, St. Steel Single Output Lobe Type			
3120	# FTR-5028 - 18Qt. (17 l.)	\$2882.25	22
3121	# FTR-5030 - 18Qt. (17 l.) w/Pressure Disc	\$3475.50	22
3122	# FTR-5034 - 36Qt. (32 l.)	\$3097.50	27
3123	# FTR-5035 - 36Qt. (32 l.) w/Pressure Disc	\$3675.00	27

Filler Unit, Single Output Lexan Hopper Gear Type			
3130	# FHP-5025 - 6Qt. (5.5 l.)	\$ 564.90	4
3131	# FHP-5026 - 18Qt. (17 l.)	\$ 523.95	6
3132	# FHP-5031 - 18Qt. (17 l.)w/Pressure Disc	\$ 675.15	6

Filler Unit, Clear Single Spout, 6Qt. (5.5 l.)			
3140	# F-5003 - 6Qt. (5.5 l.)	\$ 249.90	4
3141	# F-5007 - 18Qt. (17 l.)	\$ 288.75	6

Filler Unit Clear Double Spout			
3150	# F-5001 - 6Qt. (5.5 l.)	\$ 203.70	4
3151	# F-5005 - 18Qt. (17 l.)	\$ 240.45	6

Filler Unit Single Spout, Lexan Hopper, Lobe Type			
3160	# RP-5018 - 6Qt. (5.5 l.)	\$1655.85	10
3161	# RP-5012 - 18Qt. (17 l.)	\$1711.50	13

Filler Unit Single Output, Lexan Hopper, Gear Type			
3170	# FS-5009 - 6Qt. (5.5 l.)	\$1550.85	9
3171	# FS-5010 - 18Qt. (17 l.)	\$1606.50	12

Filler Unit Single Spout, St. Steel Hopper, Lobe Type			
3180	# RP-5019 - 10Qt. (9.5 l.)	\$2208.15	14
3181	# RP-5013 - 18Qt. (17 l.)	\$2355.15	18
3182	# RP-5023 - 18Qt. (17 l.) w/Pressure Disc	\$2570.40	18
3183	# RP-5022 - 36Qt. (32 l.)	\$2848.65	24
3184	# RP-5024 - 36Qt. (32 l.) w/Pressure Disc	\$3147.90	24

Filler Unit Single Spout, St. Steel Hopper, Gear Type			
3190	# FS-5008 - 10Qt. (9.5 l.)	\$2103.15	13
3191	# FS-5011 - 18Qt. (17 l.)	\$2250.15	17
3192	# FS-5020 - 18Qt. (17 l.) w/Pressure Disc	\$2465.40	17
3193	# FS-5021 - 36Qt. (32 l.)	\$2743.65	23
3194	# FS-5036 - 36Qt. (32 l.) w/Pressure Disc	\$3042.90	23

Spouts

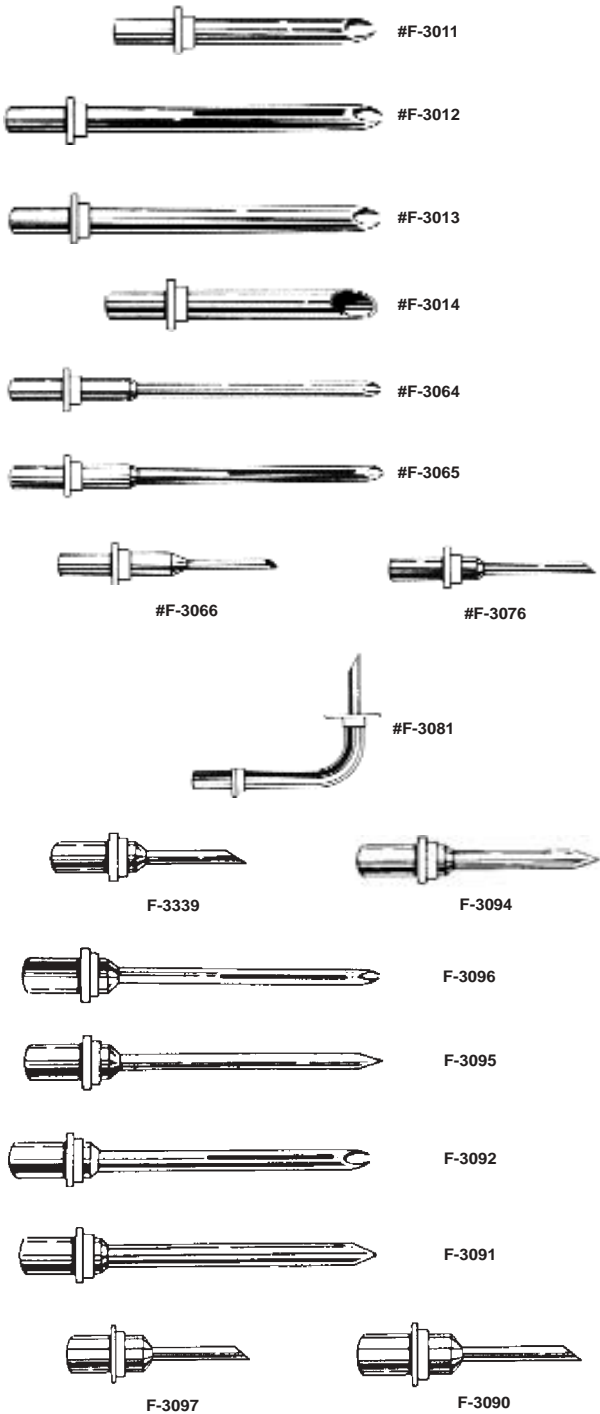

Spouts

Item #	Description	Price	Wgt
3200	Spout Standard for Double F.U., 7/16"Dia x 3 1/2" (11 dia x 89mm), # F-3011	\$14.70	3
3201	Spout Eclair - Slit for Double F.U., 7/16"Dia x 5"(11 dia x 127mm), # F-3012	\$21.00	3
3202	Spout Eclair - Plain for Double F.U., 7/16"Dia x 5" (11 dia x 127mm), # F-3013	\$18.90	3
3203	Spout Blueberry for Double F.U., 7/16"Dia x 3 1/4" (11dia x 82.5mm), # F-3014	\$18.90	3
3204	Spout Plain for Double F.U., 7/16"Dia - 5/16"Dia x 4-3/8" (11dia - 7.9 dia x 111mm), # F-3064	\$31.50	3
3205	Spout Slit for Double F.U., 7/16"Dia -5/16"Dia x 4-3/8" (11dia - 7.9dia x 111mm), # F-3065	\$34.65	3
3206	Spout Plain for Double F.U., 7/16"Dia - 3/16"Dia x 1 5/8" (11dia - 4.8dia x 41mm), # F-3066	\$28.35	3
3207	Spout 30 <sup>0</sup> Point for Double F.U., 7/16"Dia - 9/32"Dia x 2 1/4" (11dia - 7dia x 57mm), # F-3076	\$27.30	3
3208	Spout Berliner for Double F.U., 7/16"Dia -1/4"Dia x 1 5/8" (11dia - 6.4dia x 41mm), # F-3081	\$40.95	3
3209	Spout 30 <sup>0</sup> Point for Single F.U., 7/8"Dia - 3/16"Dia x 1 5/8" (22.2dia - 4.8dia x 41.1mm), # F-3339	\$51.45	3
3210	Spout Standard for Single F.U., 7/8"Dia - 7/16"Dia x 3 1/2" (22.2dia - 11.1dia x 89mm), # F-3094	\$36.75	3
3211	Spout Slit for Single F.U., 7/8"Dia - 5/16"Dia x 4 3/8" (22.2dia - 7.9dia x 111.2mm), # F-3096	\$55.65	3
3212	Spout Plain for Single F.U., 7/8"Dia - 5/16"Dia x 4 3/8" (22.2dia - 7.9dia x 111.2mm), # F-3095	\$52.50	3
3213	Spout Eclair-Slit for Single F.U., 7/8"Dia - 7/16"Dia x 5" (22.2dia - 11.1dia x 127mm), # F-3092	\$42.00	3
3214	Spout Eclair-Plain for Single F.U., 7/8"Dia - 7/16"Dia x 5" (22.2dia - 11.1dia x 127mm), # F-3091	\$40.95	3
3215	Spout 30 <sup>0</sup> Point for Single F.U., 7/8"Dia - 9/32"Dia x 2 1/4" (22.2dia - 7.1dia x 57.1mm), # F-3097	\$42.00	3
3216	Spout Blueberry for Single F.U., 7/8"Dia- 7/16"Dia x 3 1/4" (22.2dia - 11.1dia x 82.5mm), # F-3090	\$40.95	3

Filler Accessories

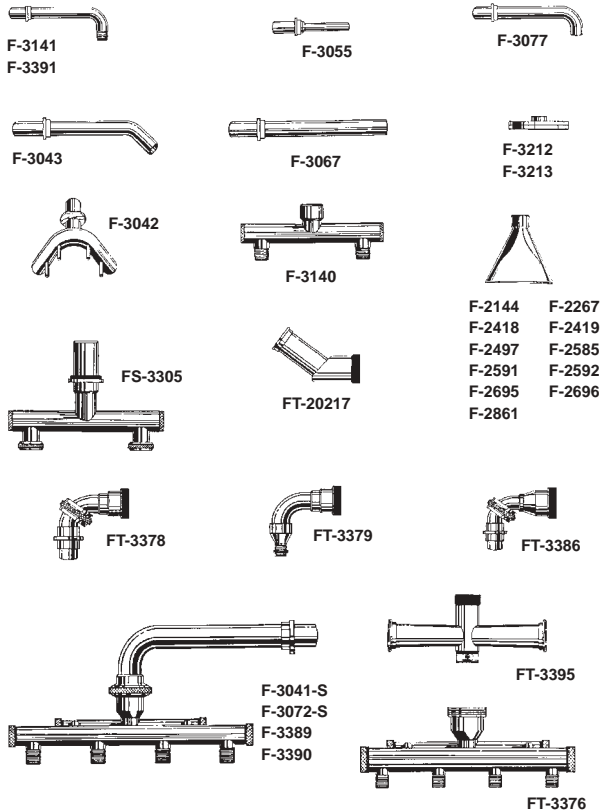

Item #	Description	Price	Wgt
3300	Extension Universal for Single F. U., 7/8" Dia (22.2 dia mm)		
3301	# F-3141 Length: 6 1/4" (158.7mm)	\$ 101.85	3
3301	# F-3391 Length: 12 1/4" (311.1mm)	\$ 114.45	3
3302	Spout Cannoli for Single F. U., 9/16"Dia x 3 "(14.3dia x 76.2mm)	\$ 87.15	3
3303	Spout 90° for Single F.U., 7/8"Dia x 6 "( 22.2dia x 152.4mm)	\$ 97.65	3
3304	Spout 45° for Single F. U., 7/8"Dia x 4 3/4 "( 22.2dia x 120.6mm)	\$114.45	3
3305	Spout Plain for Single F. U., 7/8"Dia x 7 "(22.2dia x 177.8mm)	\$ 28.35	3
3306	Spout Croissant for Single F. U., 3/16"Dia x 1 " (4.8dia x 25.4mm)	\$279.30	3

Filler Accessories

Item #	Description	Price	Wgt
3307	Spout 3 3/8"Dia x 1.62 "(85.7dia x 41.1mm) for CD-3222, F-3141, F-3257, F-3391, FS-3148	\$172.20	3
3308	# F-3212 for Bread/Roll	\$172.20	3
3308	# F-3213 for Bagel	\$172.20	3
3309	Spout Double for CD-3222, F-3141, F-3257, F-3391, FS-3148 3/4"Dia x 4 1/2" (19dia x 114.3mm) or specify	\$187.95	3
3310	Spout Layering for CD-3222, F-3141, F-3257, F-3391, FS-3148 # F-2144 0.19"W x 3.5 "L (4.8 x 89mm)	\$162.75	3
3311	# F-2267 0.28"W x4 "L (7.1 x 101.6mm)	\$170.10	3
3312	# F-2418 0.12"W x 2.36 "L (3 x 60mm)	\$153.30	3
3313	# F-2419 0.08"W x 1.6 "L (2 x 40.6mm)	\$153.30	3
3314	# F-2497 0.16"W x 1.6 "L (4 x 40.6mm)	\$153.30	3
3315	# F-2585 0.10"W x 1.97 "L (2.54 x 50mm)	\$153.30	3
3316	# F-2591 0.12"W x 2.76 "L (3x 70mm)	\$153.30	3
3317	# F-2592 0.10"W x 3.15 "L (2.54 x 80mm)	\$153.30	3
3318	# F-2695 0.14"W x 3.15 "L (3.6 x 80mm)	\$156.45	3
3319	# F-2696 0.14"W x 2.76 "L (3.6 x 70.1mm)	\$156.45	3
3320	# F-2861 0.14"W x 1.19 "L (3.6 x 30mm)	\$153.30	3
3321	Manifold - Double Spout Assembly for FS & RP Series Pumps # FS-3305	\$305.55	3
3322	Spout Batter Assembly for FT & FTR Series F.U. # FT-20217	\$132.30	3
3323	Elbow Spout for FT & FTR Series F.U., 1 7/8" dia (28.6dia mm) # FT-3378	\$204.75	3
3324	Elbow Orifice for FT & FTR Series F.U., 1 1/8" Dia (28.6dia mm) # FT-3379	\$198.45	3
3325	Elbow for FT & FTR Series F.U., 1 1/8"-7/8" (28.6-22.2 mm) Thread # FT-3386	\$196.35	3
3326	Spout Cupcake for Single F.U., 1/2"Dia (12.7dia mm) # F-3041-S Length : 3 1/4" (82.5 mm)	\$476.70	3
3327	# F-3072-S Length : 4" (101.6 mm)	\$476.70	3
3328	# F-3389 Length : 2 3/4" (69.8 mm)	\$476.70	3
3329	# F-3390 Length : 4 1/4" (108 mm)	\$476.70	3
3330	Spout Double Batter Assembly for FT & FTR Series F.U. # FT-3395	\$ 296.10	3
3331	Spout Batter Assembly for FT & FTR Series F.U., 1 1/8"Dia x 3 1/4" (28.6dia x 82.5mm) # FT-3376	\$536.55	3

Filler Accessories

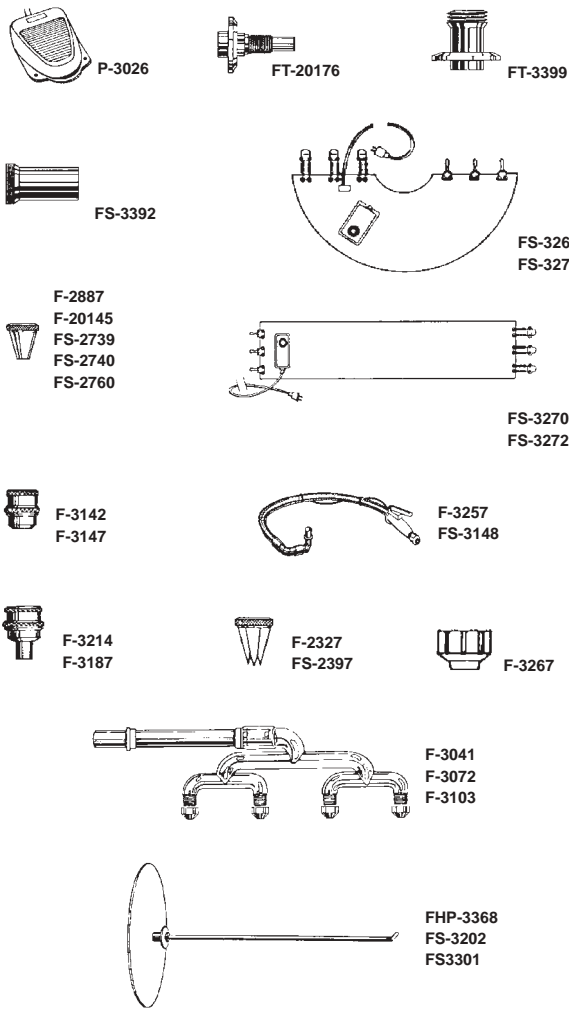

Item #	Description	Price	Wgt
3400	Switch Foot for All Power Bases, # P-3026	\$131.25	1.5
3401	Adaptor Hose for FT & FTR Series F.U. # FT-20176	\$55.65	1
3402	Adaptor 7/8"Dia Spout for FT & FTR Series F.U. # FT-3399 1 1/8"Dia (28.6dia mm)	\$187.95	3

1-877-363-6662

Filler Accessories

Item #	Description	Price	Wgt
3402-1	Adaptor 7/8"Thread, 7/8"Dia for CD--3222, F-3141, F-3257, F-3391, FS-3148 # FS-3392 7/16" - 7/8"Dia ( 11.1 - 22.2 dia mm)	\$105.00	3
3403	Heater Lower for FS & RP F.U. w/ST. Steel Hoppers # FS-3269 120V Variable	\$450.45	15
3404	# FS-3271 240V Variable	\$450.45	15
3405	Orifice for F-3140, F-3041, F-3072, F-3103 # F-2887 0.38"Dia (9.7 dia mm)	\$ 40.95	3
3406	# F-20145 0.22"Dia (5.6 dia mm)	\$ 53.55	3
3407	# FS-2739 0.56"Dia (14.2 dia mm)	\$ 52.50	3
3408	# FS-2740 0.19" x 0.38"(4.8 x 9.7 mm)	\$ 99.75	3
3409	# FS-2760 0.476"Dia (12 dia mm)	\$ 40.95	3
3410	Heater Upper for FS & RP F.U. w/ST. Steel Hoppers # FS-3270 120V Variable	\$436.80	15
3411	# FS-3272 240V Variable	\$436.80	15
3412	Valve F-3140, F-3041, F-3072, F-3103, 3/4 Dia (19 dia mm) # F-3142 Dripless	\$279.30	3
3413	# F-3214 Dripless Extended	\$ 97.65	3
3414	Valve F-3141, F-3257, F-3391, FS-3148, 7/8"Dia (22.2dia mm) # F-3147 Dripless	\$ 87.15	3
3415	# F-3187 Dripless Extended	\$ 97.65	3
3416	Hose Assy. 7/8"Dia x 36" ( 22.2 dia x 914.4mm), # F-3257 for F-5003, F-5007	\$385.35	15
3417	# FS-3148 for FS & RP F.U.	\$396.90	15
3418	Tip Decorator for F-3141, F-3257, F-3391, FS-3148 # F-2327 0.56"Dia ( 14.2 dia mm)	\$ 54.60	3
3419	# FS-2397 0.38"Dia ( 9.7 dia mm)	\$ 54.60	3
3420	Adaptor Spout for CD--3222, F-3141, F-3257, F-3391, FS-3148 , # F-3267 7/16" - 7/8"Dia ( 11.1 - 22.2 dia mm)	\$ 32.55	3
3421	Spout Cupcake for Single F.U., 1/2"Dia (12.7dia mm), # F-3041 Length : 3 1/4" ( 82.5mm)	\$242.55	3
3422	# F-3072 Length : 4" (101.6mm)	\$242.55	3
3423	# F-3103 Length : 3 1/2" (89mm)	\$242.55	3
3424	Disc Pressure # FHP-3368 for 18Qt. (17L.) FHP-SeriesF.U.	\$128.10	15
3425	# FS-3202 for 18Qt.(17L.) St. Steel Hopper	\$215.25	15
3426	# FS-3301 for 36Qt.(32L.) St. Steel Hopper	\$215.25	15



Filler Accessories

Lugs / Ingredient Bins

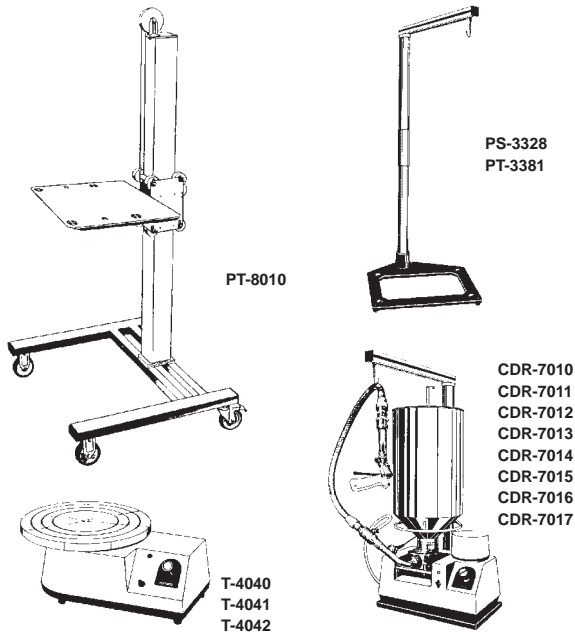

Item #	Description	Price	Wgt
<b>Cart for PT-Series Power Base, St. Steel</b>			
3500 # PT-8010		\$1543.50	30
<b>Balancer Assembly</b>			
3510 # PS-3328	for P, PS, PV Power Bases	\$ 417.90	15
3511 # PT-3381	for PT-8010	\$ 386.40	15
<b>Turntable, Speed Variable 0-42 RPM</b>			
3520 # T-4040	120V 60Hz	\$ 602.70	30
3521 # T-4041	220V 50Hz	\$ 602.70	30
<b>Cake Decorator , St. Steel Hopper, CDR PRICE RANGE</b>			
3530 # CDR-7010	120V 60Hz	\$7,100.00	55
3533 # CDR-7013	220V 50Hz	TO	55
<b>\$8,820.00</b>			
<b>PLEASE,</b>			
<b>Cake Decorator, Lexan Hopper, CONTACT US FOR</b>			
3540 # CDR-7014	120V 60Hz	PRICING	55
3543 # CDR-7017	220V 50Hz		55

**1-877-363-6662**

**Price Changes:**

In the event of market Fluctuations, our prices are subject to change without notice



**Lug  
For Preparation,  
Transportation  
& Storage  
Aluminum**

*\*Also Available in Stainless Steel*

Item #	Description	Price	Wgt
10491	16" W x 25"D x 19"H MCL19L1 1 Lug Capacity	\$ 83.68	18
10492	16" W x 25"D x 33"H MCL33L2 2 Lug Capacity, 10"Spacing	\$ 93.03	20
10493	19" W x 27"D x 41"H MCL41L3 3 Lug Capacity, 10"Spacing	\$ 99.56	22
10494	19" W x 27"D x 71"H MCL71L6 6 Lug Capacity, 10"Spacing	\$126.07	30

Polyethylene lugs for transport and storage  
all types of products , 16" x 25"

Item #	Description	Price	Wgt
9689	Gray lug	\$ 15.32	4
9689-WH	White lug	\$ 15.32	4
9690	Gray lug cover	\$ 13.42	1
9690-WH	White lug cover	\$ 13.42	1



**Bins  
to Store  
Ingredients**

Item #	Description	Price	Wgt
5000	Bin Ingredient 2.7QF	\$171.40	35
5000-1	Bin Ingredient 3.75QF	\$179.43	35
5000-2	Bin Ingredient 3.5QF	\$179.43	35
5000-3	Bin Ingredient 4.125QF	\$177.87	35
5000-1S	Bin Ingredient SS 3.75QF	\$372.63	65
5000-2S	Bin Ingredient SS 3.5QF	\$354.75	45
5000-3S	Bin Ingredient SS 4.125QF	\$413.88	86

Mixers / Spiral

Spiral Mixer



This reliable spiral mixer features a belt driven transmission and two motors, two stage for the spiral and one for the bowl. This unit is noiseless and practically maintenance free. Perfect kneading can be had with small quantities of dough or with the maximum mixer capacity. The totally enclosed bowl ensures emission free operation.

The unique design of the spiral and its coordinated speed ratio with the bowl ensure quick working times and large output for the

kneading phase. You will attain maximum oxygenation of flour and, consequently maximum water absorption. This unit also insures rising of the dough during kneading, which reduces rest time required. Dry and soft dough can be easily handled during subsequent operations.

Item #	MSM 50FB2	MSM 60FB2	MSM 80FB2	MSM 120FB1	MSM 120FB2	MSM 160FB1	MSM 160FB2	MSM 160FB2L	MSM 200FB2.5	MSM 200FB2.5L	MSM 160AE2RB	MSM 240AE3RB
Dough/lbs (Approximate)	75	112	150	225	225	300	300	300	375	375	300	450
Flour/lbs (Approximate)	50	75	100	150	150	200	200	200	250	250	200	300
Bowl Volume /Gal	21	27.73	33.55	47.81	47.81	68.68	68.68	68.68	82.42	82.42	68.68	100
Length	39.37"	42.13"	45.67"	48.43"	48.43"	55.12"	55.12"	66.93"	57.49"	68.51"	78.27"	83.86"
Width	23.23"	25.75"	27.95"	30.75"	30.75"	35.04"	35.04"	44.1"	37.41"	44.1"	51.58"	63.39"
Height	53.54"	53.54"	58.27"	58.27"	58.27"	63.19"	63.19"	122.05"	63.19"	124.02"	58.67"	65.75"
Weight/lbs	785	809	945	974	974	1554	1554	3556	1600	3667	3712	4889
Bowl Diameter	22.04"	24.8"	26.77"	29.53"	29.53"	33.47"	33.47"	33.47"	35.83"	35.83"	33.47"	39.37"
Spiral Motor KW	2/4	2/4	3.7/6.0	6	3.7/6.0	10.5	7.5/10.5	5.9/10.3	7.5/10.5	5.9/10.3	7.5/10.5	11.0/15.0
Bowl Motor/Hydraulic Motor	.55	.55	.55	.55	.55	.75	.75	.75/1.5	.75	.75/1.5	1.1/1.1	1.5/1.1
Electric Cycle	3Ph 60Hz	3Ph 60Hz	3Ph 60Hz	3Ph 60Hz	3Ph 60Hz	3Ph 60Hz	3Ph 60Hz	3Ph 60Hz	3Ph 60Hz	3Ph 60Hz	3Ph 60Hz	3Ph 60Hz

Mixers / Humidifiers

Spiral Mixer

Item #	Price	Item #	Price
MSM50FB2	\$ 7,286.00	MSM160FB2	\$11,869.00
MSM60FB2	\$ 7,435.00	MSM160FB2L	\$22,885.00
MSM80FB2	\$ 8,625.00	MSM200FB2.5	\$13,383.00
MSM120FB1	\$ 9,963.00	MSM200FB2.5L	\$23,569.00
MSM120FB2	\$ 9,963.00	MSM160AE2RB	\$22,737.00
MSM160FB1	\$11,896.00	MSM240AE3RB	\$34,318.00

Humidifier



Item #	Description	Price	Wgt
8375	Humidifier, Model PG 100 Room Capacity 1 - 6 Sq.Yds., 6.2KW	\$ 3,577.00	300
8376	Humidifier, Model PG 101 Room Capacity 6 -12 Sq.Yds., 13KW	\$ 6,520.00	600
8377	Humidifier, Model PG 102 Room Capacity 12 - 17 Sq.Yds., 19KW	\$ 8,984.00	900
8378	Humidifier, Model PG 103 Room Capacity 17 - 25 Sq.Yds., 26KW	\$11,441.00	1200

Ovens / Convection

Convection Oven w/Steam



This workhorse handles a wide variety of products. Breads, rolls, muffins, cookies, brownies, croissants, danish, bagels, pies and cakes all benefit from the uniform baking feature, which eliminates the need to rotate trays. Units may be stacked to gain maximum production from minimal space. Heavy duty 16 gauge stainless steel construction makes this a true workhorse, well suited for any commercial use. Oven light and self steam generation are standard. Tray spacing is 3.5". Custom configurations are available.

Convection Oven w/Steam

Item #	Description	Price	Wgt
4120	Oven, 8 Pan Capacity 220V/3Ph	\$6,480.00	650
7420	Oven, 8 Pan Capacity 460V/3Ph	\$6,980.00	650

Convection Oven Options

8116	Digital Thermostat	\$ 160.67	1
8115	Casters w/Locks	\$ 84.70	11
8119	Oven Stand on legs, plain	\$ 385.59	32
8119-SL	Oven Stand on legs w/8 slides	\$ 399.19	79
8119-SH	Oven Stand on legs w/2 shelves	\$ 423.23	79
8119-SLWH	Oven Stand on Casters w/8 slides	\$ 467.69	76
8119-SHWH	Oven Stand on Casters w/2 shelves	\$ 494.12	85
8120	Seaworthy Crate	\$ 159.23	50

Automatic Underbuild Proofer

6965	Proofer, 16 Pan Capacity 220V/3Ph	\$3,592.00	400
------	-----------------------------------	------------	-----

Proofer Options

8114	Humidistat instead of Infinity Switch	\$ 203.16	2
8115	Casters w/Locks	\$ 84.70	11
8120	Seaworthy Crate	\$ 159.23	50



Convection Oven with optional proofer

NOTE: 7" Required behind the oven for steam exhaust and air circulation.

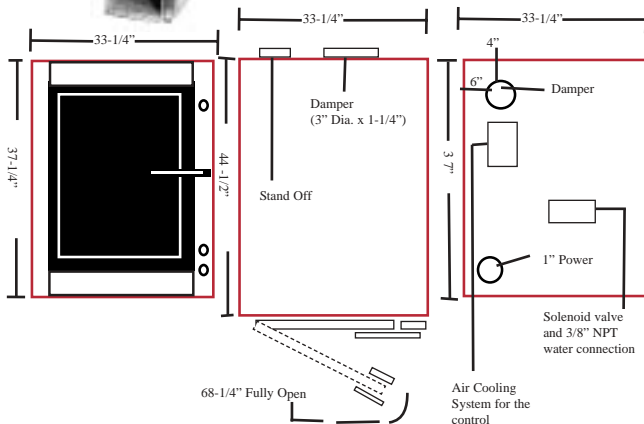

48

Divider Rounder / Auto & Semi-Auto

Divider - Rounder



AUTOMATIC DIVIDER ROUNDER



SEMI - AUTOMATIC DIVIDER ROUNDER

Semi Automatic Divider-Rounder

Item #	Description	Price	Piece Weight
MSDR4.5-9	9 Part	\$5,832.00	7.05-17.63oz
MSDR3.6-10	10 Part	\$5,832.00	5.29-12.07oz
MSDR3.7-12	12 Part	\$5,832.00	4.59-10.94oz
MSDR3.8-18	18 Part	\$5,832.00	2.99-7.41oz
MSDR3.8-22	22 Part	\$5,832.00	2.29-6.17oz
MSDR2.8-30	30 Part	\$5,832.00	1.05-3.35oz
MSDR3.9-30	30 Part	\$5,832.00	1.58-4.59oz
MSDR2.7-36	36 Part	\$5,832.00	0.88-2.65oz
MSDR3.8-36	36 Part	\$5,832.00	1.05-3.7oz
MSDR2.7-50	50 Part	\$5,832.00	0.70-1.04oz
MSDR3.8-50	50 Part	\$5,832.00	0.88-2.65oz
MSDR2.2-144	144 Part	\$6,804.00	0.28-.53oz

Power Specifications: Single Phase Power Optional, 220V, 3PH, 60Hz, 0.75KW, 22.83"L x 24.01"W x 59.45"H (23.62"L x 25.59"W x 66.93"H Crated)

Automatic Divider-Rounder

Item #	Description	Price	Piece Weight
MADR4.5-9	9 Part	\$11178.00	7.05-17.63oz
MADR3.6-10	10 Part	\$11178.00	5.29-12.07oz
MADR3.7-12	12 Part	\$11178.00	4.59-10.94oz
MADR3.8-18	18 Part	\$11178.00	2.99-7.41oz
MADR3.8-22	22 Part	\$11178.00	2.29-6.17oz
MADR2.8-30	30 Part	\$11178.00	1.05-3.35oz
MADR3.9-30	30 Part	\$11178.00	1.58-4.59oz
MADR2.7-36	36 Part	\$11518.20	0.88-2.65oz
MADR3.8-36	36 Part	\$11178.00	1.05-3.7oz
MADR2.7-50	50 Part	\$11178.00	0.70-1.04oz
MADR3.8-50	50 Part	\$11178.00	0.88-2.65oz
MADR2.2-144	144 Part	\$15147.00	0.28-.53oz

Power Specifications: Single Phase Power Optional, 220V, 3PH, 60Hz, 1.85KW, 22.83"L x 24.01"W x 59.45"H (23.62"L x 25.59"W x 66.93"H Crated)

49

# 1-877-363-6662

## PREP AND GLAZE

SOME PANS ARE AVAILABLE PLAIN OR WITH A FDA-ACCEPTED SILICONE BAKERY RELEASE COATING CALLED PREP & GLAZE (P&G). GLAZE IS ACTUALLY A TWO PART PROCESS. THE FIRST PART OF THE PROCESS IS CALLED PREP.

THIS STEP PREPARES THE PAN'S SURFACES , ALLOWING THE SILICONE TO ADHERE TIGHTLY TO THE PAN'S SURFACES. THE SECOND STEP (GLAZE) IS THE ACTUAL APPLICATION OF THE CLEAR SILICONE COATING. THIS COATING HELPS BAKED PRODUCTS RELEASE FROM THE PAN EASILY WHEN PANS ARE NEW. AS THE GLAZE WEARS OFF, THE PANS MUST BE OILED MORE AND MORE FREQUENTLY UNTIL FINALLY THE GLAZE IS TOTALLY WORN OFF AND THE PAN MUST BE OILED EVERY TIME IT IS USED. INDEPENDENT COMMERCIAL REGLAZING BUSINESSES ARE AVAILABLE TO CLEAN AND REGLAZE USED BAKERY PANS. ASK YOUR INEQCO REPRESENTATIVE FOR THE LOCATION NEAREST TO YOU.

**We accept Visa, Mastercard,  
American Express, and Discover**

**Price Changes:**

In the event of market Fluctuations, our prices are subject to change without notice

## GLAZED BAKEWARE HANDLING AND CLEANING GUIDELINES

All pans with Prep & Glaze have a silicone glaze coating applied to the surface of the pan to aid in the removal of baked products. Because this silicone glaze is not a permanent coating, the use and care suggestions listed below should be followed in order to prolong the life of the glaze.

### DAILY USE

**1. Lubricate pans.** Prior to panning the products to be baked, apply a pan lubricant or spray to the baking area(s) of each pan. Brand new or newly reglazed pans generally do not require as much lubrication as older pans. Brand new glazed pans work best after first lubricating the pan's baking contact surfaces and then baking for ten minutes, without any product in the pan.

**2. Depan products quickly.** Baked products should be depanned immediately after baking while the pan is still hot or warm. If you allow baked products to cool in the pan, steam from the product will penetrate the glaze. This may cause glaze lifting or premature glaze failure and can actually result in damage to the pan's surface.

3. Do not scratch or scrape pans. Do not use metal utensils or other objects that could scratch the glaze. Deep scratches may cause surface corrosion on the pan.

### DAILY CLEANING

**1. Clean as you go.** Usually, just wiping still-warm pans with a clean towel is all that is necessary. Sometimes it helps to apply a little pan lubricant or non-stick spray to the towel first. Avoid pan washing whenever possible,

**2. Wash with mild soap & water only when absolutely necessary.** Only mild soap and water should be used when washing commercial baking pans. Do not use harsh cleaners, highly alkaline detergents or abrasive scrubbing pads. Use of these materials will damage the glaze and cause the glaze to fail prematurely. Thoroughly dry all pans immediately after washing - warm ovens work well. After every washing, reseason baking surface(s) immediately with pan lubricant or spray and bake at 350F for ten minutes. Follow pan storage guidelines.

**NOTE: Do not soak pans in water. Do not wash in automatic dishwashers.**

**3. Once dry, store pans upside down.** Do not nest pans immediately after towel drying. Keep pans away from moist and humid storage environments. The best storage areas are dry, warm storage areas or still-warm ovens.

## THE MOST IMPORTANT SAFETY TIP IS PROPER MAINTENANCE ITSELF

Users are responsible for the proper operation and maintenance of the manual material handling equipment they use. Some equipment will quickly become damaged and unsafe if abused or subjected to improper demands. If equipment is regularly maintained and not abused, you will get the maximum safety and service performance from your casters. \*Do not overload equipment \*Do not drop heavy loads on carts or trucks \*Do not use at high speeds These uses create severe impact and shock loads that may lead to wheel and equipment failure.

## FRAMES AND FASTENERS

Periodically turn the equipment on its end or side and check the following: \*Look for broken welds or deck boards. \*Tighten loose bolts and nuts. \*Look for frame distortion caused by overloads and impact loads. Distorted frames can lead to wheel failure by placing disproportionate loads on one or two casters. \*If casters are stem types (bolted or riveted in place), make certain that the legs of the equipment are not bent, and that mounting bolts are securely fastened. \*Always use lock-nuts or lock washers in mounting casters. \*Be sure casters with expanding applicators in tubular equipment are held firmly in place.

## LUBRICATION

Lubrication is essential. The lubrication schedule depends on your specific application. Normal conditions may warrant lubrication every six months, but monthly lubrication may be necessary for applications in wet or corrosive environments. Lubrication may be required after each cart washing. Special high temperature, water-resistant lubricants must be used for these applications. Ineqco can provide stainless steel casters that require less maintenance in frequent cart-washing applications.

Regular lubrication adds to the life of wheel and swivel bearings. A little lube spillover to friction points on the wheel hub, thrust washer, and leg surface of straight roller bearing systems reduces drag and improves rollability.

## WHEELS

Check wheels for visible tread wear. Flat spots may indicate accumulation of foreign material, such as string or thread, which can cause the wheel to bind. Remove the axle bolt and nut. Clean out foreign material and check internal components for wear or failure. Re-assemble if the parts are not damaged. Thread guards may be installed to delay build-up if foreign material is a continuing problem.

Loose casters and frozen wheels can also cause flat spots. Proper maintenance, especially tightening of bolts, proper lubrication, and replacement of damaged casters will enhance equipment rollability and tracking performance.

Badly worn or "chunked out" rubber tires can also cause erratic steering, bumping, load shifting, and floor damage. Replacement wheels and bearings should be kept on hand to reduce costly downtime.

After wheels have been inspected and repaired, be sure the axle nut is properly tightened. Use lock washers or locknuts on all axles. If the caster axle is loose, tighten immediately. The wheel may be damaged or lock up if it is cocked in the caster horn.

## CASTERS

Check the swivel assembly to see if there is excessive play due to wear. If the swivel assembly is loose, it is advisable to replace it (fork or rig) or the entire caster. If the caster has a king bolt and nut, make sure it is fastened securely. If the swivel does not turn freely, check for corrosion or dirt binding the raceways. Again, it may be necessary to replace the swivel assembly or the entire caster.

If the equipment has rigid or stationary casters at one end, make sure that the caster horns are not bent or distorted.

# 1-877-363-6662

**GLOSSARY OF CASTER TERMINOLOGY**

**BOLT HOLE SPACING -**

The distance between top plate bolt hole centers

**CAPACITY -**

Maximum load per wheel based on expected operation (expected maximum load divided by number of wheels)

**CASTER SIZE -**

Same as wheel diameter

**DYNAMIC OR ROLLING LOAD -**

Load on a caster or wheel while in motion

**FORK ASSEMBLY (RIG) -**

The caster assembly without wheel and axle

**MOUNTING (TOP) PLATE -**

The plate at the top of the caster which is bolted or welded to the equipment

**OFFSET -**

Horizontal distance between the centerline of the swivel kingpin and the centerline of the axle; shorter offsets are stronger, longer offsets improve maneuverability.

**RACEWAY -**

Surface on which bearing rollers or balls move

**ROLLABILITY -**

Force required to begin or maintain motion, measured by drawbar pull

**SPANNER BUSHING -**

The fixed sleeve in which the axle runs

**STATIC LOAD -**

Load on a caster or wheel while at rest

**SWIVEL RADIUS -**

Horizontal distance between the centerline of the swivel kingpin and the outside edge of the wheel

**THRUST WASHER -**

The washer between the wheel hub and the inside of the caster leg

**TREAD WIDTH (FACE) -**

Width of the wheel tread

**CASTER ORDERING GUIDE**

WHEN ORDERING REPLACEMENT CASTERS, PROVIDE AS MANY OF THE FOLLOWING SPECIFICATIONS AS POSSIBLE

- |                                     |                                    |
|-------------------------------------|------------------------------------|
| <u>A</u> WHEEL DIAMETER             | <u>F &amp; G</u> BOLT-HOLE SPACING |
| <u>B</u> OVER-ALL HEIGHT            | <u>H</u> TREAD WIDTH               |
| <u>C</u> SWIVEL RADIUS              | <u>J</u> HUB LENGTH                |
| <u>D, E, I</u> TOP PLATE DIMENSIONS |                                    |

- A \_\_\_\_\_  
 B \_\_\_\_\_  
 C \_\_\_\_\_  
 D \_\_\_\_\_ X E \_\_\_\_\_  
 F \_\_\_\_\_ X G \_\_\_\_\_  
 H \_\_\_\_\_  
 J \_\_\_\_\_

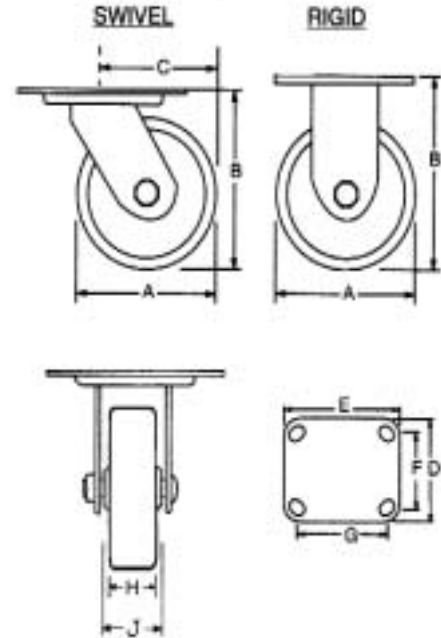

**APPENDIX C  
SPECIAL FABRICATION**

Ineqco is currently supplying oven racks for most of the foreign and domestic oven manufacturers. You can order them in knock - down or nesting configuration.

If you need oven racks not listed in our directory, please contact Ineqco at 1-877-363-6662.



## Terms And Conditions

Ineqco Intl LLC, Terms and Conditions of Sale: Product(s) have been sold to the Buyer on these Terms and Conditions of Sale. Acceptance: Buyer's action in acceptance of all of the Terms and Conditions set forth by Ineqco Intl LLC, hereafter referred to as Ineqco. If any of the Buyer's terms are in conflict with these Terms and Conditions of Sale, the terms of Ineqco shall govern, unless buyer's terms are accepted in writing by Ineqco. No verbal agreement or understanding shall in any way modify the Terms and Conditions of Sale contained herein.

**DELIVERY:** Unless otherwise specified, in writing, by Ineqco, all prices are F.O.B. manufacturers warehouse: Transportation will be by method, route and carrier selected by Ineqco. All freight charges will be the responsibility of the buyer. Buyer shall bear (or shall reimburse Ineqco) for all taxes and/or excises or other government charges or levies. Ineqco shall not be liable for delay in or failure of delivery where delivery has been made impossible or impractical by the occurrence of a contingency such as war, intervening government regulations, civil commotion, riot, disorder, strike or other labor stoppage or difficulty, fire, flood, storm, accident, production failure, raw material shortage, transportation failure or act of God. In any event, Ineqco may, at its sole discretion allocate products among buyers. Ineqco's count of goods shipped shall govern except in case of proven error.

**DAMAGED MERCHANDISE:** Our responsibility for shipment ceases with acceptance by carriers. If any goods called for on the Bill of Lading are short or damaged, do not accept them until the freight agent makes a damage notation on your freight bill. Thoroughly inspect the shipment as soon as received- if any concealed loss or damage is discovered, notify your freight agent at once and request an inspection. This is absolutely necessary. Unless you do this, the transportation company will not entertain any claim for loss or damage. If the agent will not make an inspection, then; you should make an affidavit that you notified him (on a certain date) and he failed to do so. This, with other papers, will properly support your claim.

**CLAIMS PROCEDURES:** In no event shall Ineqco be liable on any claim unless written notice of the claim, sent certified mail, return receipt requested, is received by Ineqco within thirty (30) days after delivery. Failure of Buyer to assert claim within such time shall be deemed a waiver by the buyer of all claims with respect to such products. Buyer shall have the right to reject nonconforming products or to make claim for monetary adjustment, or at Ineqco's option, to return nonconforming goods and disputed products to Ineqco but, (1) in no event shall any claim of any kind be greater than the purchase price of the product in respect of which damages are claimed, and (2) in no event may any product be returned to Ineqco without Ineqco's prior written consent. Buyer shall afford Ineqco prompt and reasonable opportunity to inspect all material as to which any claim is made. No claim shall be allowed after the product has been processed in any manner.

**PAYMENTS:** Terms are 50% deposit with order balance prior to or on delivery unless previous credit terms are arranged. Interest shall be charged at the rate of 1.75% per month, or maximum allowed by law, whichever is greater, from the due date on all past due accounts. If, in the judgment of Ineqco, the financial credit of the Buyer at any time does not justify continuance of production or shipment of the product based on payment terms herein specified, Ineqco may require full or partial payment prior to completion or shipment.

**INDEMNITY:** In addition to each and every item and condition herein which refers to some type of indemnity requirement of Buyer in favor of Ineqco, Buyer shall exculpate, defend indemnity and hold harmless Ineqco for all losses, damages or liabilities resulting. Ineqco warrants to the original purchaser that its equipment will be free from defects in the material and/or workmanship for the period of one (1) year from the date of original invoice, provided the equipment is reported installed on a registration card and returned to Ineqco. The purchaser is responsible for; having the equipment properly installed, operated under normal conditions with proper supervision and the performance of periodic preventive maintenance. Ineqco obligation under this warranty shall be replacement or repair of defective parts within the warranty period. After thorough examination, the decision of Ineqco's service department shall be final. Any defective parts to be repaired or replaced must be returned to Ineqco within thirty (30) days of installation of the replacement part, transportation charges are to be prepaid, and the parts must be properly packaged and tagged.