

Engineering Services

Example

Clients task us to complete individual engineering phases to managing all details from:

- **project programming,**
- **detailed design,**
- **coordination drawings,**
- **procurement,**
- **equipment manufacturing, an**
- **onsite startup.**

In Tool Development, we assisted others in:

- **HAZ-OPS and safety reviews, and**
- **CE, SEMI S2 and UL compliance.**

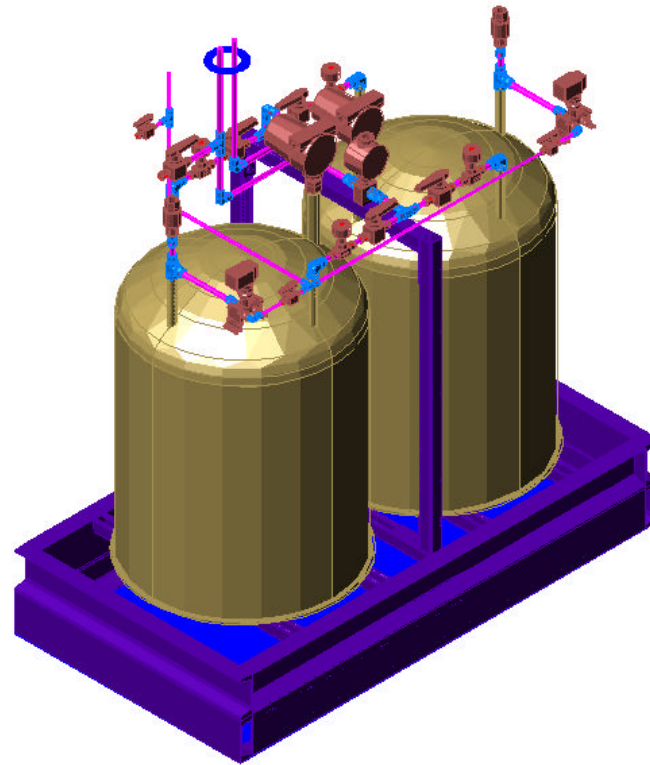

PTS

Engineering

Confidential Material

Reproduction, copying or redistribution is prohibited.

1/7/2003

Turnkey Chemical Systems

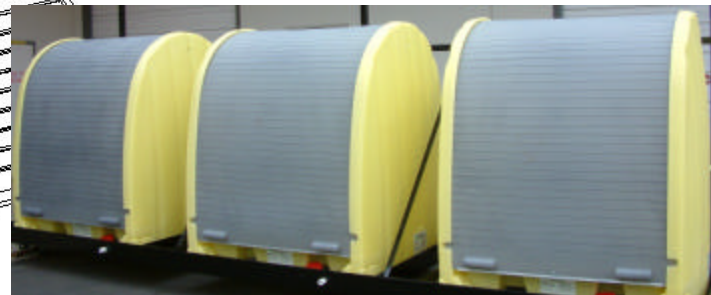
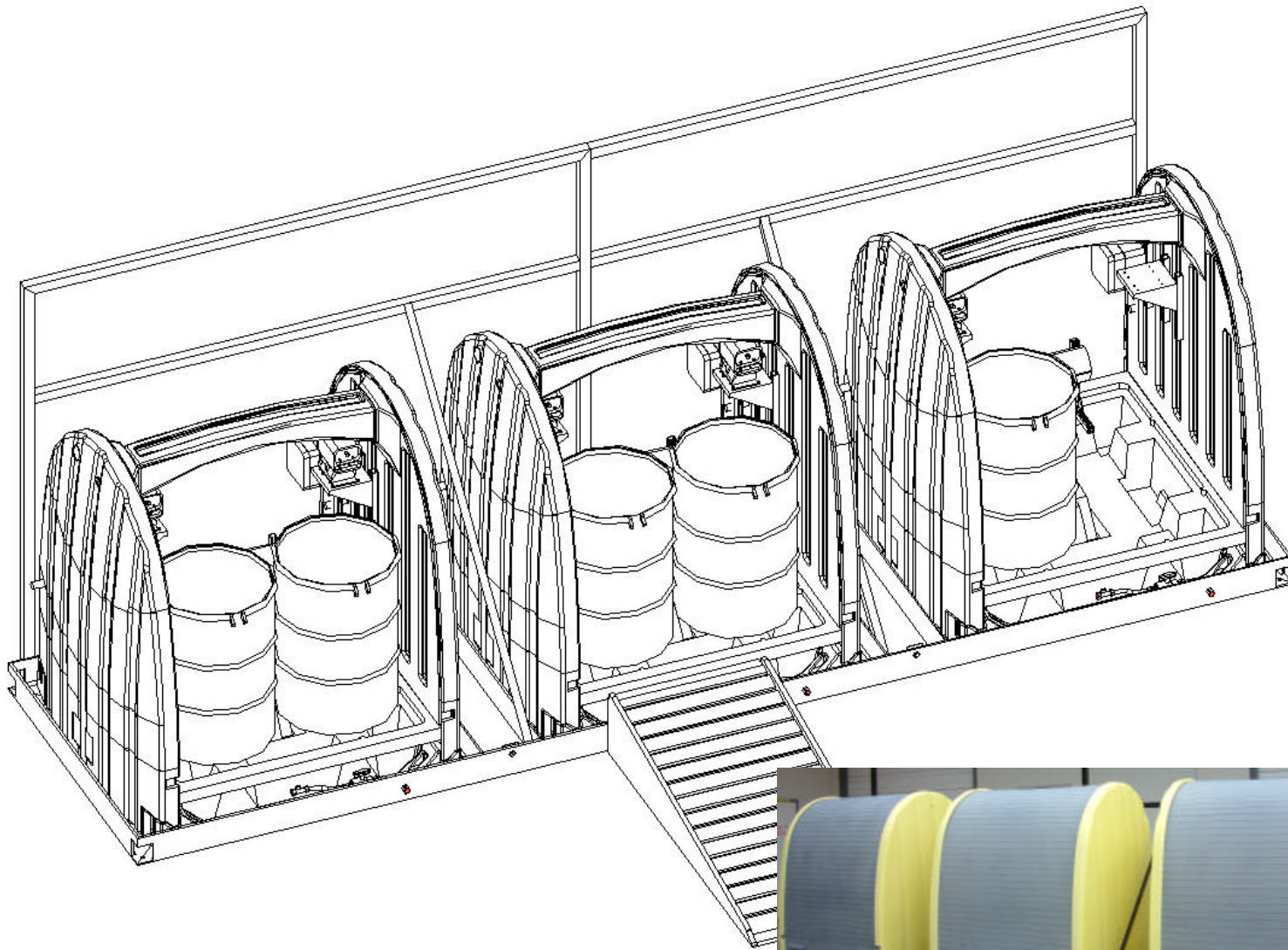

P
En

Confidential Material

Reproduction, copying or redistribution is prohibited.

1/7/2003

Multi Discipline Designs

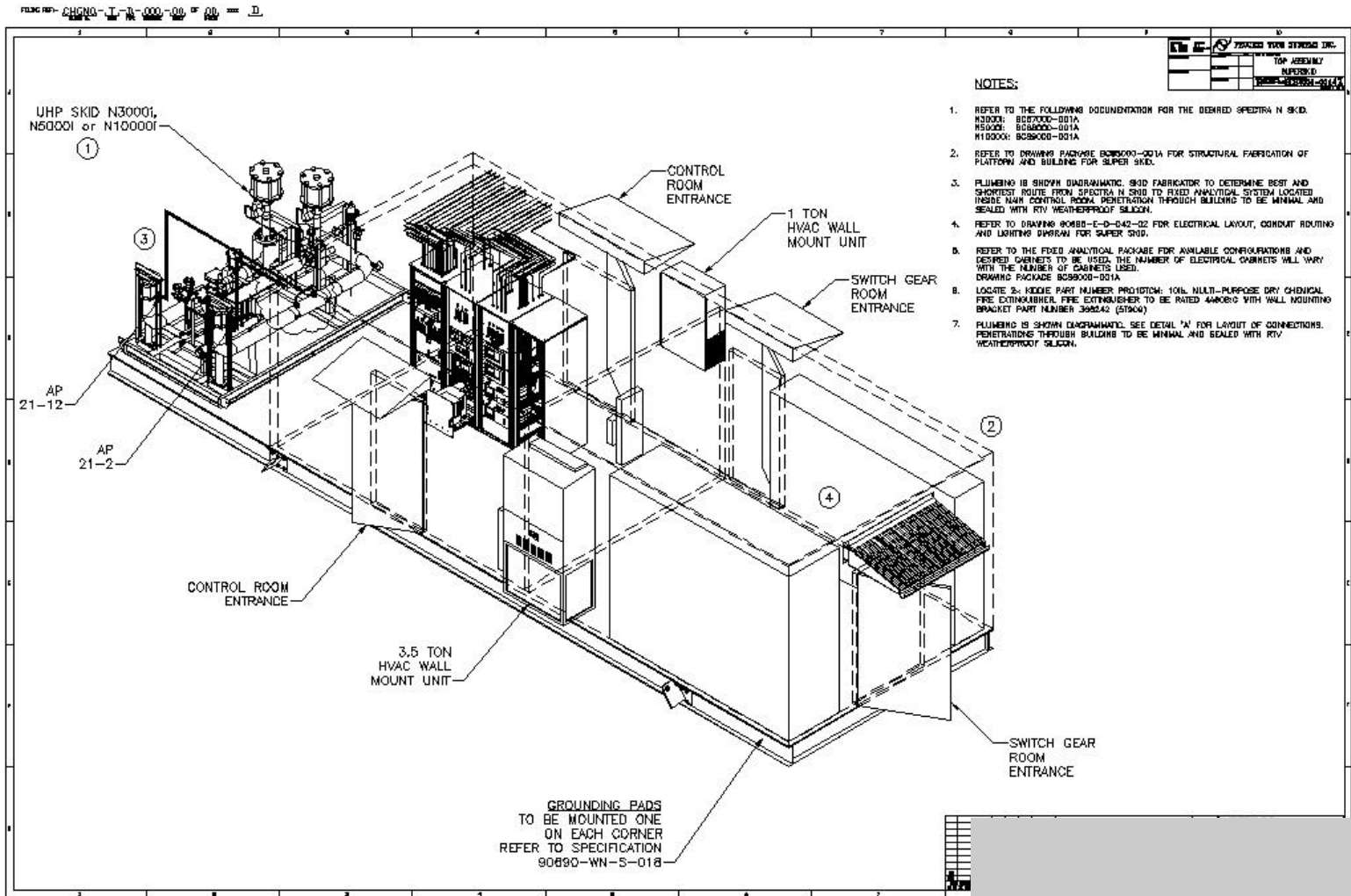

Engineering

Confidential Material

Reproduction, copying or redistribution is prohibited.

1/7/2003

2002 Engineering Projects

2002 Tool Development Projects

Fluorine Generator for chamber cleaning design included vessels, specialty alloys with heat lots, airflow modeling, seismic

Three Chemical Delivery System

300 mm Metal Electrofill System Redesign

Bulk Chemical Delivery, Dispense and Waste Collection Systems for Large Bio Research Facility

Germanium Tetrachloride Dispense System

Solvent Purification System

Liquid Precursor Production Fill Line

Liquid Precursor Purification/Recirculation System

Large Vacuum Dry down chamber

HCL Delivery Cabinet



PTS

Engineering

Confidential Material

Reproduction, copying or redistribution is prohibited.

1/7/2003

Engineering Projects

2001 Tool Development Projects

300 mm RTP Development-new gas box

300 mm Wet Cleaning Tool Bench-
collaborative design from P&ID to
Production-plastics PTFE & PDVF,
temperature control, chemical metering and
vaporization

300 mm CVD Process - collaborative design
from P&ID to Production mechanical,
electronics, enclosure, safety

CO2 Purification designed vessels,
refrigeration, condensers, exchangers,
electrical, controls and structure

300 mm Mask Cleaners designed cooling,
sheetmetal, chamber

300 mm MOCVD Furnace Gas Module

Inert Gas manifolds for rocket assist
for Military

IPA Purification

Sulfuric Acid Metering System

TEOS Dispensing System

Air Separation Plant Control Room

Plasma Tool Research Bench

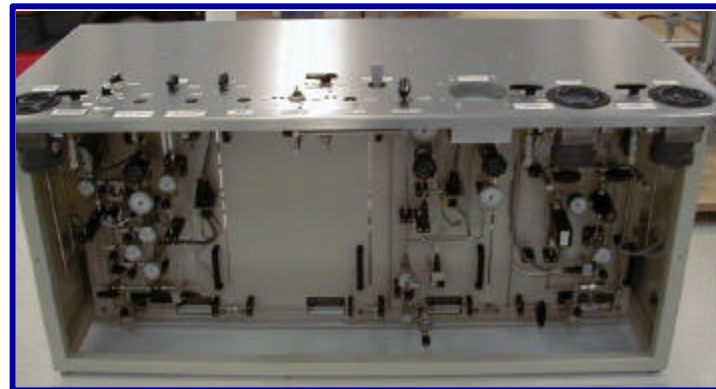

PTS

Engineering

Confidential Material

Reproduction, copying or redistribution is prohibited.

1/7/2003

Equipment P&ID to Product

Automatic Purge & Fill Pressure Control

Level control Continuous Fill Alarming

SEMI S2 NRTL Cert. Life Safety Controls

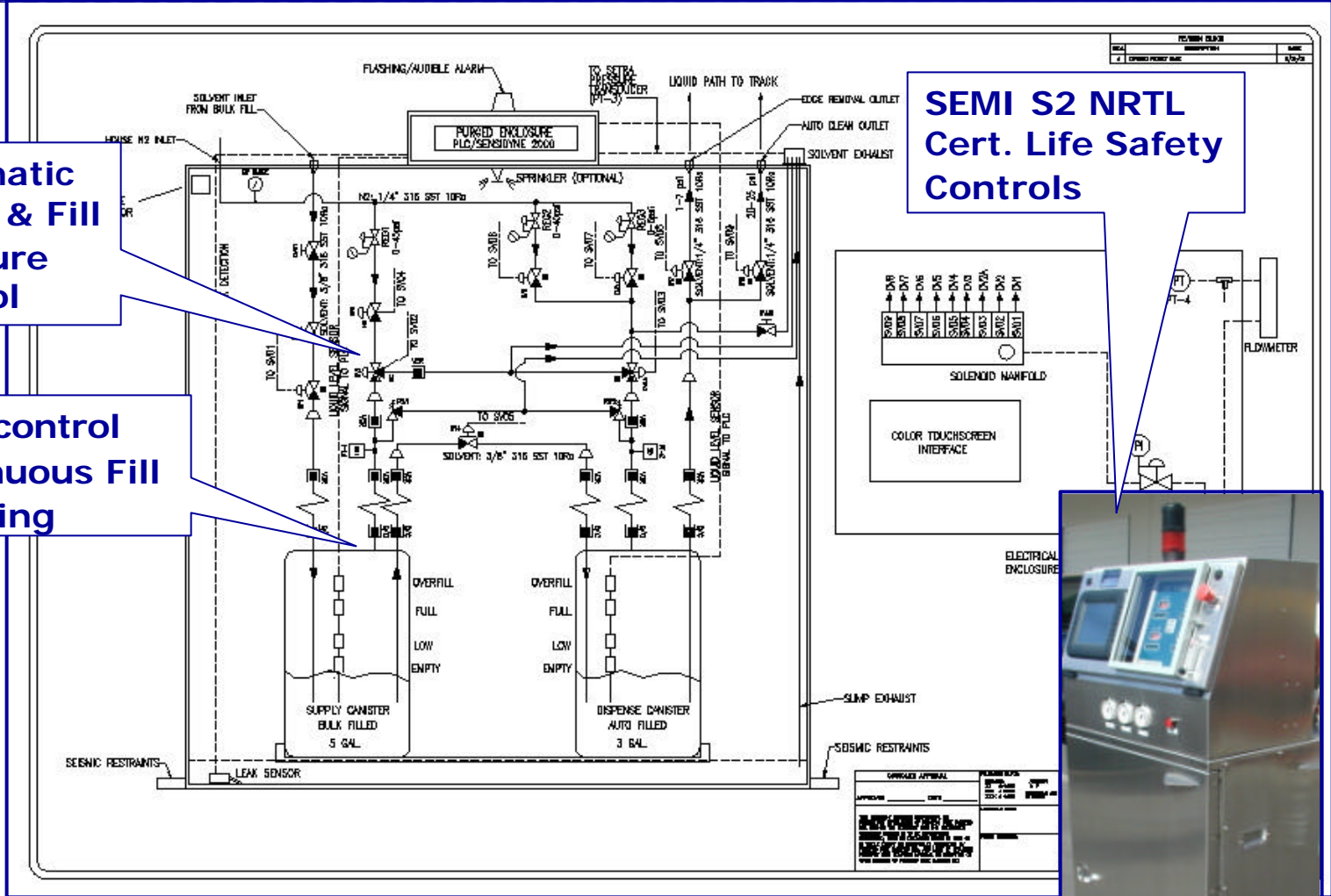

PTS
Engineering
 Confidential Material
 Reproduction, copying or redistribution is prohibited.
 1/7/2003

3-D Design & Detailed BOM's

Design Services

- UHP Gas & Chemical Systems
- Lethal Gas Service
- Controls
- Electronics
- Chemical Processing Equipment

④⑤⑥ NOT SHOWN FOR CLARITY
REV 3:

BOM TABLE			
QTY	DESCRIPTION	REV	DATE
1	VALVE	0	1/1/00
1	GAS INLET	0	1/1/00
1	GAS OUTLET	0	1/1/00
1	VALVE	0	1/1/00

50	1/2" NPT-1/2" NPT	1/2" NPT-1/2" NPT	BRASS	0
48	1/2" NPT-1/2" NPT	1/2" NPT-1/2" NPT	BRASS	0
48	1/2" NPT-1/2" NPT	1/2" NPT-1/2" NPT	BRASS	0
47	1/2" NPT-1/2" NPT	1/2" NPT-1/2" NPT	BRASS	0
46	1/2" NPT-1/2" NPT	1/2" NPT-1/2" NPT	BRASS	0
45	1/2" NPT-1/2" NPT	1/2" NPT-1/2" NPT	BRASS	0
44	1/2" NPT-1/2" NPT	1/2" NPT-1/2" NPT	BRASS	0
43	1/2" NPT-1/2" NPT	1/2" NPT-1/2" NPT	BRASS	0
42	1/2" NPT-1/2" NPT	1/2" NPT-1/2" NPT	BRASS	0
41	1/2" NPT-1/2" NPT	1/2" NPT-1/2" NPT	BRASS	0
40	1/2" NPT-1/2" NPT	1/2" NPT-1/2" NPT	BRASS	0
39	1/2" NPT-1/2" NPT	1/2" NPT-1/2" NPT	BRASS	0
38	1/2" NPT-1/2" NPT	1/2" NPT-1/2" NPT	BRASS	0
37	1/2" NPT-1/2" NPT	1/2" NPT-1/2" NPT	BRASS	0
36	1/2" NPT-1/2" NPT	1/2" NPT-1/2" NPT	BRASS	0
35	1/2" NPT-1/2" NPT	1/2" NPT-1/2" NPT	BRASS	0
34	1/2" NPT-1/2" NPT	1/2" NPT-1/2" NPT	BRASS	0
33	1/2" NPT-1/2" NPT	1/2" NPT-1/2" NPT	BRASS	0
32	1/2" NPT-1/2" NPT	1/2" NPT-1/2" NPT	BRASS	0
31	1/2" NPT-1/2" NPT	1/2" NPT-1/2" NPT	BRASS	0
30	1/2" NPT-1/2" NPT	1/2" NPT-1/2" NPT	BRASS	0
29	1/2" NPT-1/2" NPT	1/2" NPT-1/2" NPT	BRASS	0
28	1/2" NPT-1/2" NPT	1/2" NPT-1/2" NPT	BRASS	0
27	1/2" NPT-1/2" NPT	1/2" NPT-1/2" NPT	BRASS	0
26	1/2" NPT-1/2" NPT	1/2" NPT-1/2" NPT	BRASS	0
25	1/2" NPT-1/2" NPT	1/2" NPT-1/2" NPT	BRASS	0
24	1/2" NPT-1/2" NPT	1/2" NPT-1/2" NPT	BRASS	0
23	1/2" NPT-1/2" NPT	1/2" NPT-1/2" NPT	BRASS	0
22	1/2" NPT-1/2" NPT	1/2" NPT-1/2" NPT	BRASS	0
21	1/2" NPT-1/2" NPT	1/2" NPT-1/2" NPT	BRASS	0
20	1/2" NPT-1/2" NPT	1/2" NPT-1/2" NPT	BRASS	0
19	1/2" NPT-1/2" NPT	1/2" NPT-1/2" NPT	BRASS	0
18	1/2" NPT-1/2" NPT	1/2" NPT-1/2" NPT	BRASS	0
17	1/2" NPT-1/2" NPT	1/2" NPT-1/2" NPT	BRASS	0
16	1/2" NPT-1/2" NPT	1/2" NPT-1/2" NPT	BRASS	0
15	1/2" NPT-1/2" NPT	1/2" NPT-1/2" NPT	BRASS	0
14	1/2" NPT-1/2" NPT	1/2" NPT-1/2" NPT	BRASS	0
13	1/2" NPT-1/2" NPT	1/2" NPT-1/2" NPT	BRASS	0
12	1/2" NPT-1/2" NPT	1/2" NPT-1/2" NPT	BRASS	0
11	1/2" NPT-1/2" NPT	1/2" NPT-1/2" NPT	BRASS	0
10	1/2" NPT-1/2" NPT	1/2" NPT-1/2" NPT	BRASS	0
9	1/2" NPT-1/2" NPT	1/2" NPT-1/2" NPT	BRASS	0
8	1/2" NPT-1/2" NPT	1/2" NPT-1/2" NPT	BRASS	0
7	1/2" NPT-1/2" NPT	1/2" NPT-1/2" NPT	BRASS	0
6	1/2" NPT-1/2" NPT	1/2" NPT-1/2" NPT	BRASS	0
5	1/2" NPT-1/2" NPT	1/2" NPT-1/2" NPT	BRASS	0
4	1/2" NPT-1/2" NPT	1/2" NPT-1/2" NPT	BRASS	0
3	1/2" NPT-1/2" NPT	1/2" NPT-1/2" NPT	BRASS	0
2	1/2" NPT-1/2" NPT	1/2" NPT-1/2" NPT	BRASS	0
1	1/2" NPT-1/2" NPT	1/2" NPT-1/2" NPT	BRASS	0

PTS

Engineering

Confidential Material

Reproduction, copying or redistribution is prohibited.

1/7/2003

Vessel Design

You can receive built to order ASME vessels from stainless steel or specialty alloys and have vessels designed to a variety of operating temperature & pressure ranges

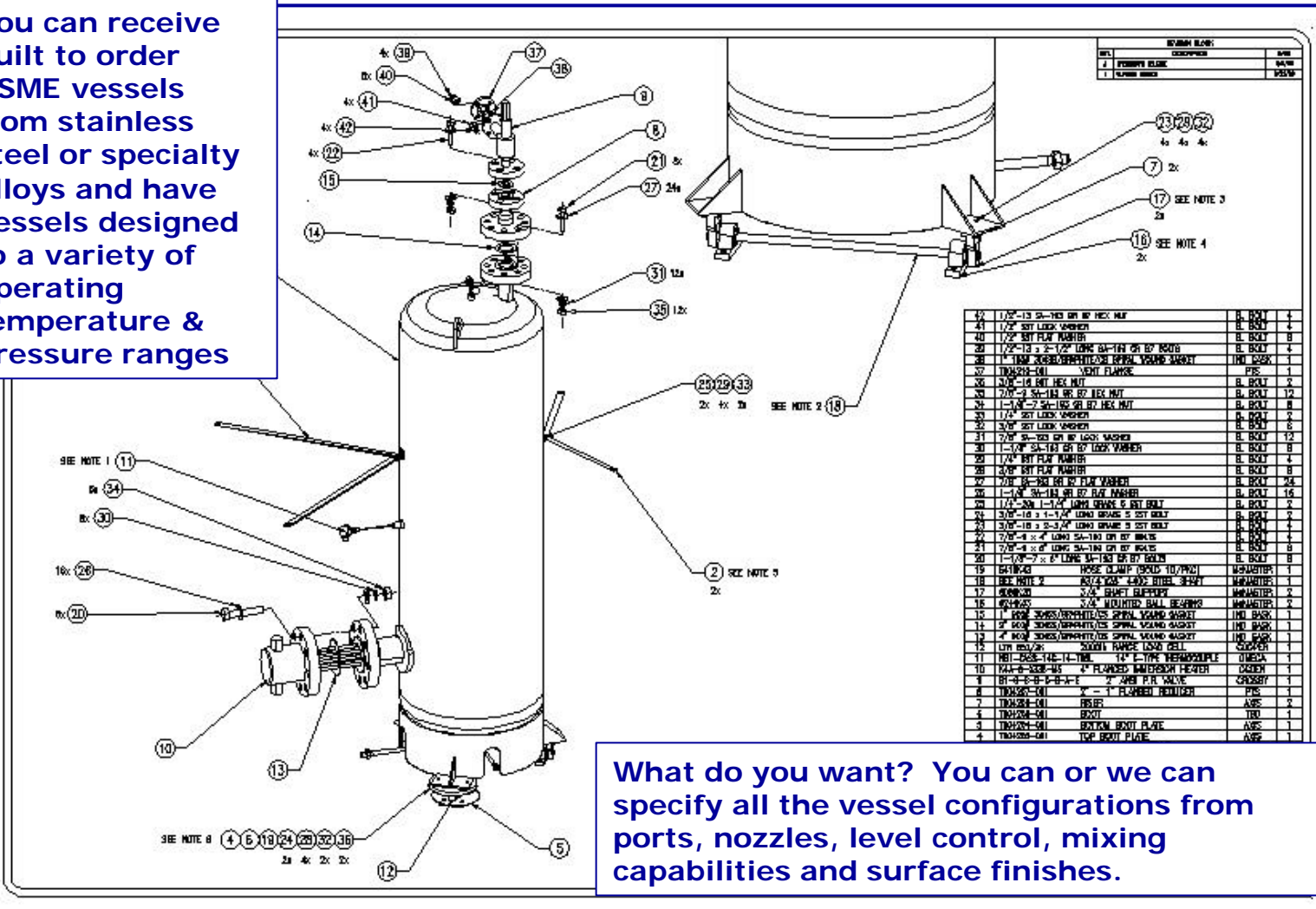

What do you want? You can or we can specify all the vessel configurations from ports, nozzles, level control, mixing capabilities and surface finishes.

PTS

Engineering

Confidential Material

Reproduction, copying or redistribution is prohibited.

1/7/2003

Sheet Metal Design & Enclosures

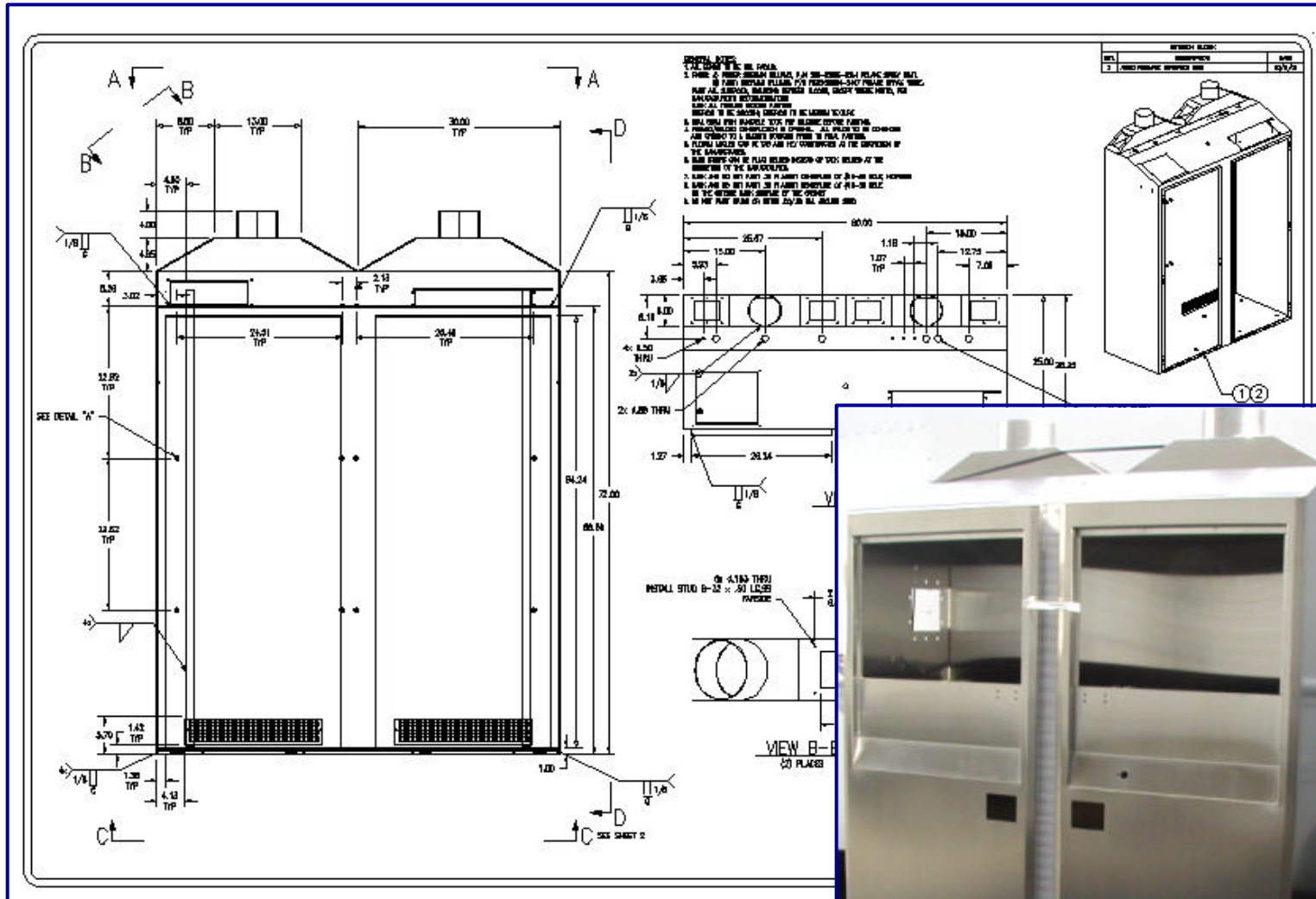

PTS

Engineering

Confidential Material

Reproduction, copying or redistribution is prohibited.

1/7/2003

Controls & Electrical Design

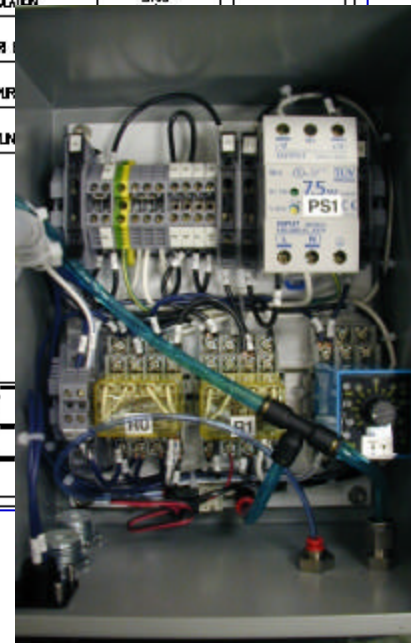
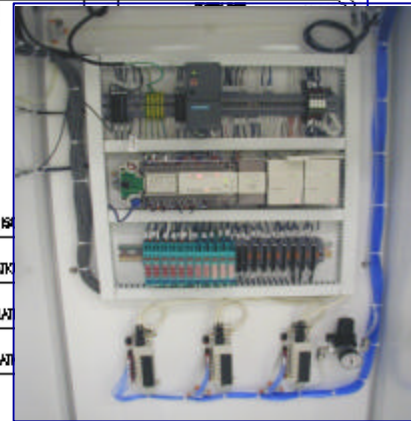
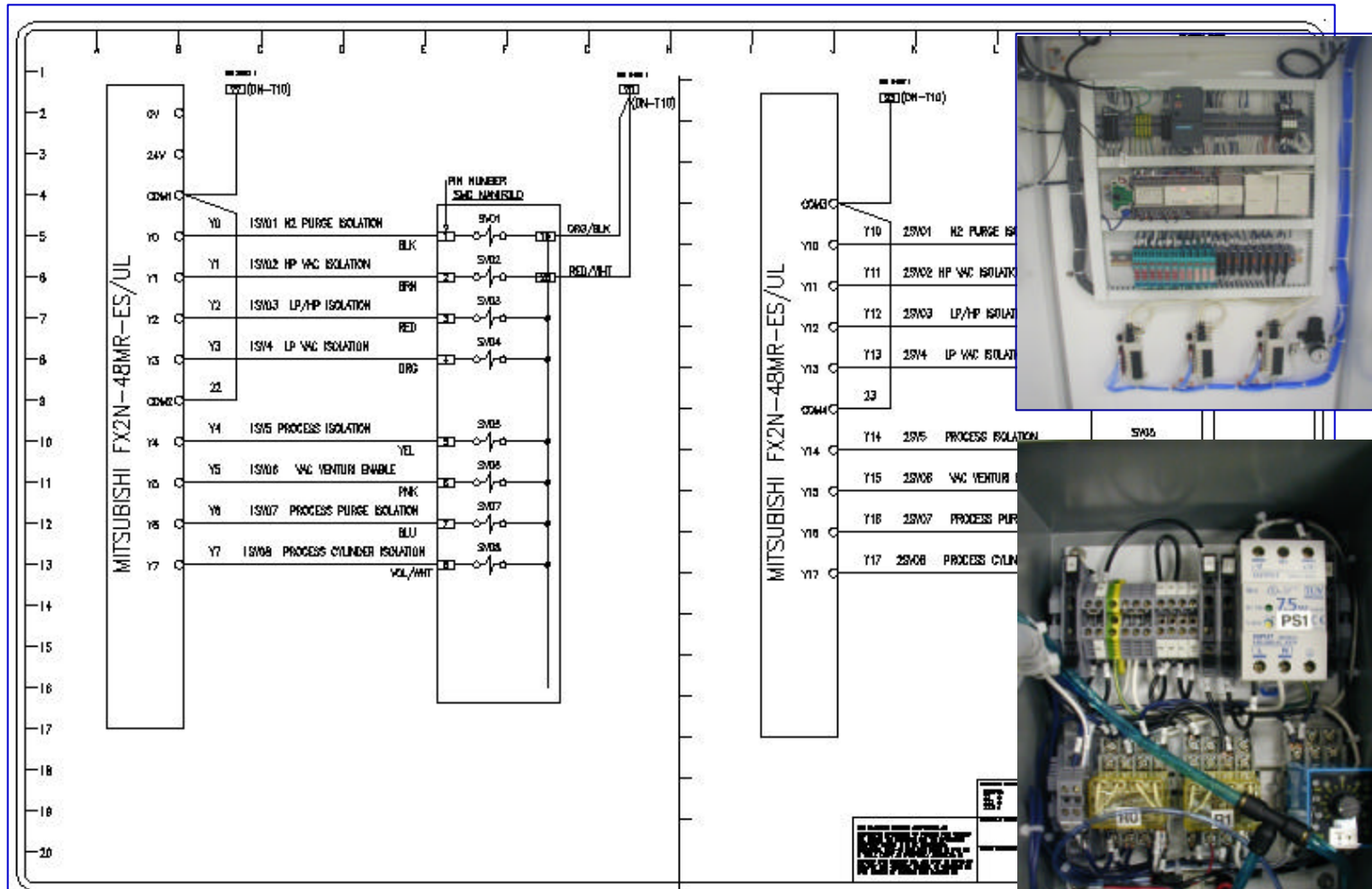

PTS

Engineering

Confidential Material

Reproduction, copying or redistribution is prohibited.

1/7/2003

Frame Fabrication & Design

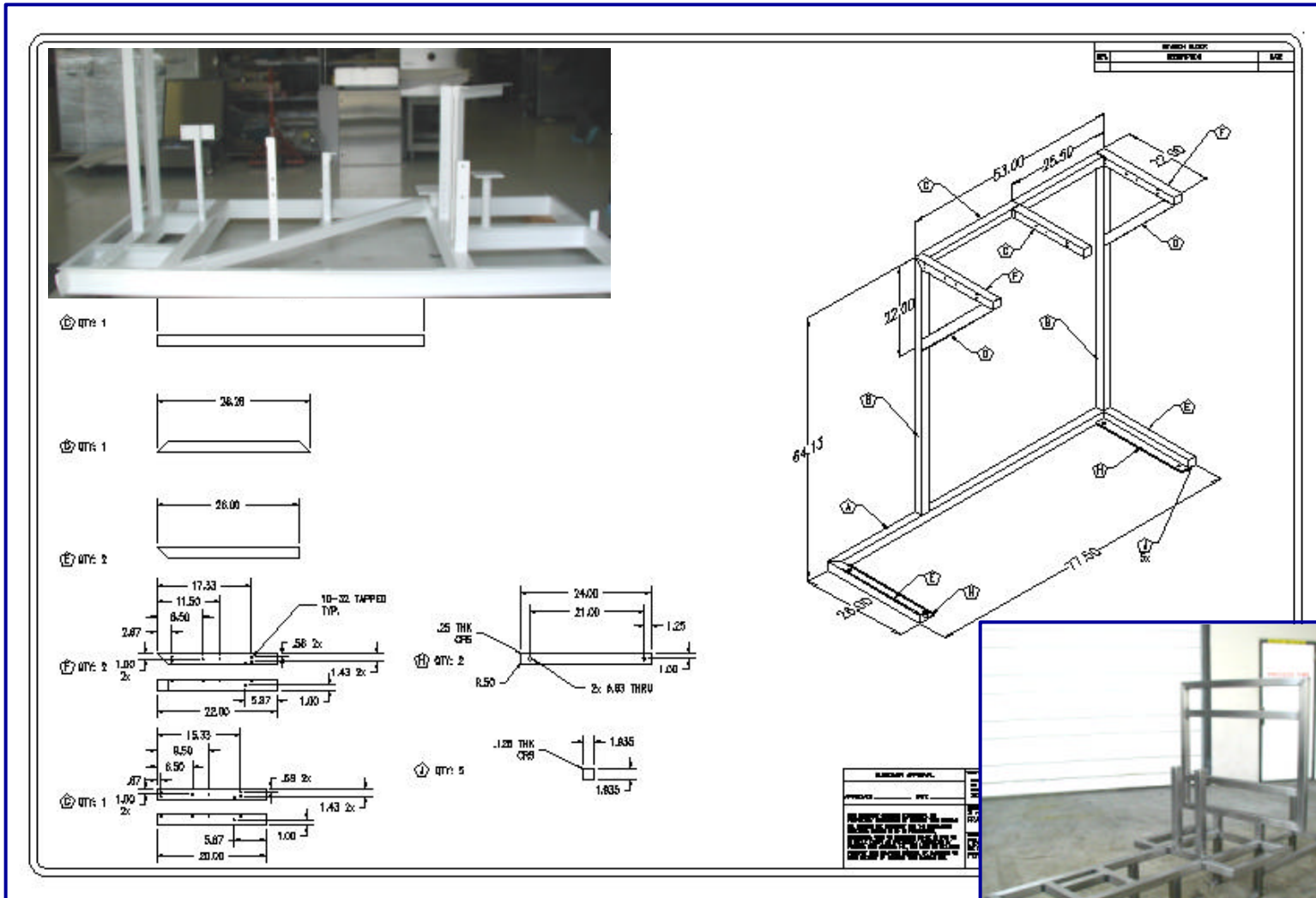

PTS

Engineering

Confidential Material

Reproduction, copying or redistribution is prohibited.

1/7/2003