

Engineering Tomorrow's Communications



Innovative Concepts, Inc. is a communications technology development firm specializing in the research, design, development, production, and support of wire less data communications product and services. Dedicated to delivering innovative products and services to the defense community, Innovative Concepts, Inc. collaborates with its customers to help them communicate more effectively and operate more efficiently.

Our expertise includes: the product suite of IDM Technology™, software and systems engineering, hardware development, and aerospace technical services.

With strong industry knowledge and an expert team of engineers on staff, Innovative Concepts, Inc. is committed to:

- Completely satisfying every customer requirement.
- Ensuring the highest quality in the research, design, development, production, and support of all our products and services.
- Consistently achieving superior, cost-effective results for our customers while adhering to our high standards of quality, dedication and integrity.
- Building lasting value for our customers.

At - a - Glance

- Virginia Corporation Formed in 1985
- Privately Held, Consistently Profitable, Small Business
- Sales in FYE September 2002: \$16 MM
- Targeted Sales for FYE September 2003: \$26MM
- Current Employment Level: ~ 85 Personnel
- ISO 9001 Certified; CMMI Level III in Process
- USG Cleared Facilities located in McLean, VA
- Global Customer Base
- Focused on Defense Community

IDM Technology™

Mobile, Interoperable, and Reliable Data Communications.

Innovative Concepts, Inc. developed IDM Technology™ to remedy data communication problems within the military. Through IDM Technology™, all aspects of the battlefield - aviation units, ground forces, and shipborne systems can communicate with one another. IDM Technology™ provides a seamless data communication solution. We offer the following IDM Technology™ products and services:

- IDM V304™
- BlueTAC™
- IDMSIM™
- Software-Based Solutions™
- SCIDM™
- MiIX™ PTS
- PCIDM™
- Integration Support for IDM Technology™

IDM Technology™ is in use by all U.S. Army Aviation platforms, F-16s, EA-6Bs, JSTARS, Rivet Joint, as well as several NATO platforms.

www.innocon.com



Photos provided by U.S. Department of Defense
Copyright © Innovative Concepts, Inc. All rights reserved.

Company History



Since 1985, Innovative Concepts, Inc. has been developing innovative products and providing expert engineering services. Through the years, we have established ourselves as a force in the areas of data communications, space systems, and space sciences/radiation effects. Innovative Concepts, Inc. has engaged in hundreds of successful research, design and development projects for many diverse customers. Our greatest strength has always been our unique staff of highly skilled professionals who consistently produce superior, cost-effective results for our customers.

Over the past ten years, Innovative Concept, Inc. has been best known for its data communications product suite, IDM Technology™. IDM Technology™ remedies data communication problems within the military. Through IDM Technology™, all aspects of the battlefield – aviation units, ground forces, and shipborne systems can communicate with one another. IDM Technology™ provides the military with one seamless communication solution.

The first IDM Technology™ product developed, the Improved Data Modem (IDM V302), went into production in 1993 and was installed on 2700 aircraft worldwide. It has been very successful as a ground-to-air and ground-to-ground data connection for the military. Currently, IDM Technology™ includes six product lines.

In its early years, Innovative Concepts, Inc. focused on space programs – in space systems and space sciences engineering. The space systems engineering group successfully developed custom solutions for the United States Naval Research Laboratory on space based communications projects such as: the Naval EarthMap Observer (NEMO), Constellation Side Emulator (CSE), and the Data Handling Unit (DHU).

The space sciences group, focusing on aerospace engineering consulting and technical services, still has a strong presence in the company today. Innovative Concepts, Inc. delivers analysis, measurements, testing, assessments, modeling, and predictions for government, commercial, and international aerospace programs.

Innovative Concepts, Inc. is pleased to state unequivocally that its customers, past and present, have benefited greatly from our support and contributions in the development of communications technology. Our expert staff is committed to further developing IDM Technology™ and our engineering services well into the future.

www.inncon.com



The Management Team

Dr. Andy Feldstein **President & Chief Executive Officer (CEO)**

Dr. Andy Feldstein is the President and CEO of Innovative Concepts, Inc. Under his leadership, Innovative Concepts, Inc. has maintained an impressive history of consistent success and continues to flourish and grow in today's changing technological environment. Andy oversees the formation and functions of all business divisions within the company, and provides vision and strategic planning for the company's future. Since its inception in 1985, Innovative Concepts, Inc. has enjoyed a profit margin every year, and continues to strive for constant success in its expert engineering products and services.

Andy has over twenty years of diverse management experience within the high-tech industry. He has extensive experience in technical and project management. In addition, he has great knowledge of corporate management, including strategic planning, finance, personnel and business development. Andy has maintained a highly visible reputation for excellence both as a corporate leader and as a professional within the technical community.

Prior to founding Innovative Concepts, Inc., Andy was a manager of the Satellite Communications Systems Division at M/A-COM Linkabit's Eastern Operations. Under his direction, the Satellite Communications Systems Division developed several programs key to the company's success. Before joining M/A-COM, Andy was a Project Manager at Wilson Hill Associates, where he planned, designed, and pursued technical development efforts.

He received a Master of Science degree and a Doctor of Science degree in Electrical Engineering from George Washington University in Washington, DC. In addition, Andy holds a Bachelor of Science degree in Electrical Engineering from The Pennsylvania State University in University Park, Pennsylvania. ■

Mr. Tom Curtis **Chief Operating Officer (COO)**

Mr. Tom Curtis is the COO of Innovative Concepts, Inc. As COO, Tom is responsible for the company's business development, finance, engineering, and programs divisions.

Tom created a structured approach to program management, implementing disciplined and comprehensive cost, schedule and financial controls. He directs seventy world class real-time communications engineers in the research, development, test and support of communications hardware and software. Tom joined the company in 2001, and served as Vice President of Programs before becoming the COO.

Mr. Tom Curtis continued on following page.

w w w . i n n o c o n . c o m



The Management Team

Mr. Tom Curtis continued from previous page

Tom's accomplishments include twenty years of exceptional leadership and achievement in all facets of program management. His major strengths are concurrent engineering, communications, financial management, team building, and risk management.

Before joining Innovative Concepts, Inc., Tom served twenty-eight years in the U.S. Navy as an instructor pilot, test pilot, aerospace engineer and program manager. His last assignment was as program manager for a major defense acquisition program to develop two new helicopters to accomplish the U.S. Marine Corps' attack and light utility missions.

Tom received a Bachelors degree from the University of Georgia, a Masters degree in Management from Central Michigan University and a Masters degree in Aerospace Engineering (Avionics) from the Naval Postgraduate School. Additionally, Tom is a graduate of the Naval Test Pilot School and the Defense Systems Management College (in both the Advanced and Executive Program Management Courses). ■

Mr. Richard Harrison **Vice President, Corporate Business Development**

Mr. Richard Harrison joined Innovative Concepts, Inc.'s executive team in March 1998 as its first Vice President of Programs. In October 1999, Richard formed the IDM Technology™ Products Group to exploit Innovative Concepts, Inc.'s leading edge abilities in tactical data communications and to establish the company's products and services in the global marketplace. In October 2002, he assumed the role of Vice President of Corporate Business Development. Richard continues to lead the charge to brand the company's unique capabilities in tactical communications and wireless data communications, ensuring the company's influence is felt in the tactical data link community.

His professional background spans thirty years and includes executive management positions for various sized organizations in corporate and government, public and private, and foreign and domestic industries. In addition, he has founded two private companies. Richard is a hands-on executive with an entrepreneurial nature and a sense of organizational purpose and determination. His background covers the full area of corporate management, including organizational infrastructure, financial management, market development, program management and sales.

Richard obtained a Bachelor of Arts degree from the University of Virginia and a Master of Arts degree in Management from Central Michigan University. ■



Product Highlights

- Lightweight Tactical Modem
- Six Channel Interface
- Provides Digital Data Connectivity
- Memory Expansion Capabilities

Improved Data Modem V304™ (IDM V304™)

What is IDM V304™?

The IDM V304™ is a lightweight, six-channel tactical modem in SEM-E-form providing both modem and digital routing connectivity between and among airborne and ground platforms using existing radios and/or crypto equipment.

This IDM Technology™ product is not only fully compatible with the commercial Internet; it can also transmit and receive any data format designed for use over Internet Protocol-based networks. IDM V304™ seamlessly interconnects major military networks for both maneuver and fire support. In addition, this product provides critical linkage to several existing legacy systems and can be user-enhanced to incorporate others.

Supports Legacy and Software Defined Radios

IDM V304™ works with legacy radios but is also compatible with any RF device that conforms to the Software Communications Architecture (SCA) Level 2.2. More importantly, Innovative Concepts, Inc.'s support for this architecture is broad and on-going. As a result, all IDM Technology™ products will evolve with this standards base for software defined radio interoperability.

Delivers Internet Protocol (IP)

IDM Technology™ employs internet technology as a practical tool in battle space management. IDM V304™ delivers IP capability both to the cockpit and to virtually any command and control center. IP-based processing as implemented via IDM Technology™, permits rapid, accurate target acquisition, assessment, and engagement; efficient fire support synchronization; and a significant reduction in the potential for friendly fire incidents. By adopting digital data transfer over RF using IP, situational awareness is dramatically enhanced and friendly unit location information can be automatically updated and displayed to all units. This provides commanders the reliable information they need to gain an understanding of what is happening in the battle space in real-time.

U.S. Army Uses IDM V304™

The U.S. Army was quick to recognize the advantages of eliminating the need of voice commands in tactical missions and has designated IDM Technology™ for installation on every helicopter in the Army inventory, including the Apache Longbow, Kiowa Warrior, Chinook, and Blackhawk. The new RAH-66 Comanche will receive a software-only version of the IDM Technology™ for use in its Integrated Communications and Navigation system (ICNIA).

Please see reverse for technical information.

www.innocon.com
8200 greensboro drive suite 700 mclean va 22102 sales@innocon.com 703.893.2007

Copyright © Innovative Concepts, Inc. All rights reserved.

IDM TECHNOLOGY™

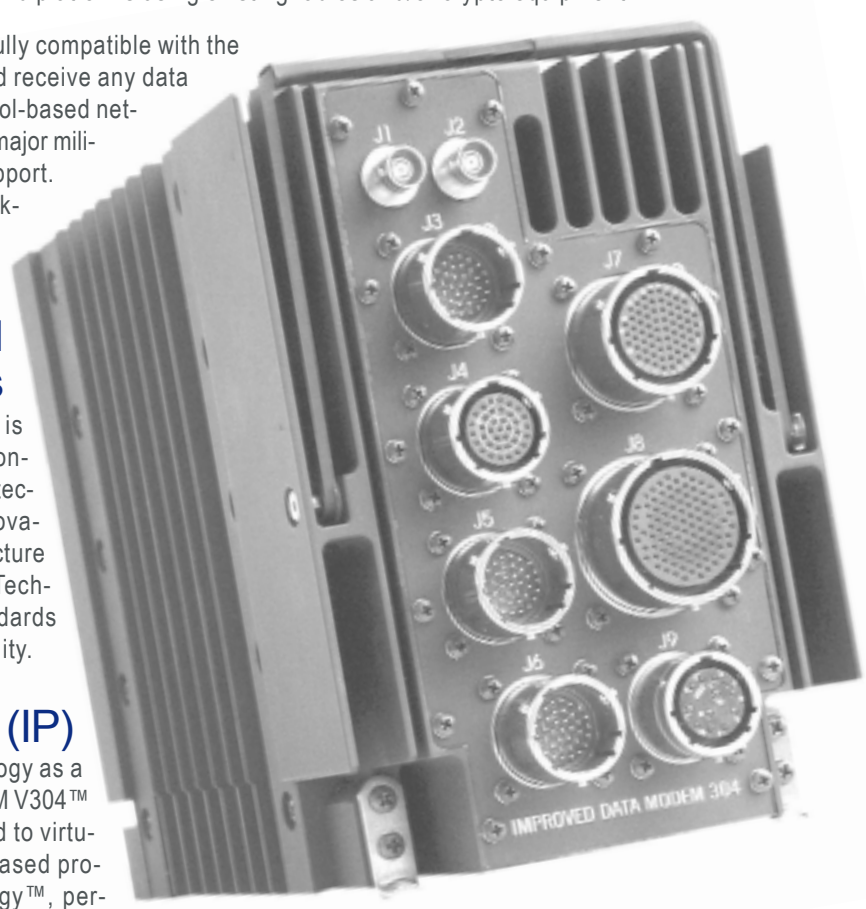

Key Features

Interoperability

- MIL-STD-188-220B/C
- AFAPD (USAF)
- TACFIRE (Army)
- Joint Variable Message Format (JVMF)*

IDM V304™ Radio Interface Connections

- ARC-164 (HAVEQUICK II)
- ARC-182
- ARC-186
- ARC-201 (SINGARS)
- ARC-201D (SINGARS SIP)
- ARC-210
- ARC-220
- ARC-222 (DRA functions)
- EPLRS*
- KY-58*
- L-Band Transceiver

IDM V304™ Platform Interface Connections

- MIL-STD-1553B
- 10Base-T Ethernet
- USB
- RS 232

Analog Port (CPSK, FSK)

- Data Rate: 75, 150, 300, 600, 1.2k, 2.4k bps
- Tone Pairs: 1300/1700, 1300/2100, 1200/2400

Digital Port (ASK)

- Data Rate: 1.2k, 2.4k, 4.8k, 8k, 9.6k, 16k bps
- Channel Bandwidth: 20 kHz
- Input Signal Level: 0.1-25 Vpp
- Output Signal Level: 1-12 Vpp

Other

- Weight: ≤ 16 lbs.
- Part Number: 81995-DM-001-304
- Nomenclature: Modem, Communications MD-1359/A
- NSN: 5895-01-493-4396
- Tray Wt. 0.8 +/- 0.2
- Dimensions: 9.0"W x 7.42"H x 5.35"D
- Expansion: 3 Spare Slots, Memory Expansion Capability
- Reliability: Demonstrated 5,000+ Hours
- Supportable: 3-Level Maintenance Compatible
- Service Life: 20 Years

System Architecture

Input/Output Module (IOM)

- Uses latest Digital Signal Processor technology to modulate and demodulate messages
- IOM can modulate or demodulate four half-duplex channels simultaneously at data rates up to 16k bps
- Includes all discrete signals required to interface to a variety of radios and can be programmed to support virtually any radio interface

Communications Processor Module (CPM)

- Uses a 400 MHz embedded Intel Pentium microprocessor capable of simultaneously processing six radio channels for message transmission.
- Receives and transmits messages, and processes configuration commands via MIL-STD-1553B or CORBA over Ethernet

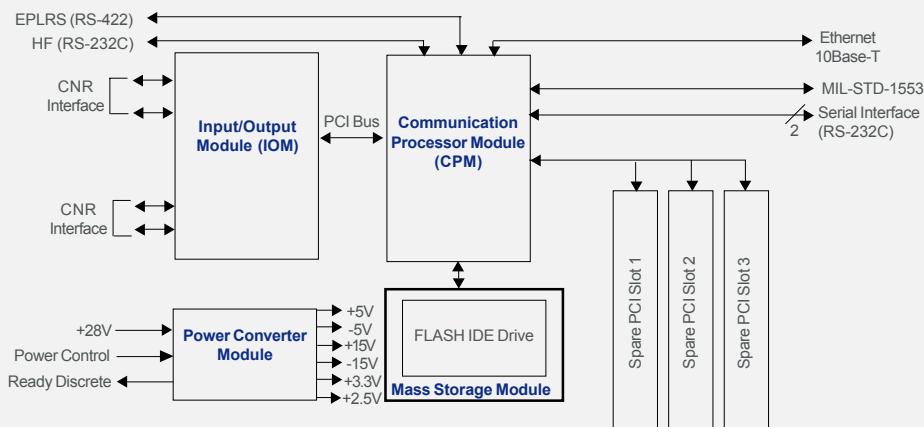

Mass Storage Module (MSM)

- Supports a 256 Mb IDM flash fault tolerant disk drive system

Software Loads

- Mission software loaded via Ethernet Port

Power Converter Module

- Accepts and filters 28 Vdc from the platform
- Provides power to the modules within the IDM V304™
- MIL-STD-704 C/D

*Subject to U.S. Government Approval.



Product Highlights

- Simulator Environment for IDM Technology™ Users
- Provides Real-Time Training Environment
- Ensures Units are Prepared for Critical Missions

IDMSIM™

Training Environment

Creating the most realistic training environment possible is essential to ensure our units are well prepared to complete their missions. This can be a difficult and costly task. To assist IDM Technology™ users in completing this mission, Innovative Concepts, Inc. offers IDMSIM™. The IDMSIM™ allows students to gain the experience they need in executing specific real world missions and rehearse the use of IDM data messaging.

The IDMSIM™ replaces the avionics IDM package with a personal computer (PC) hardware suite for use in simulator environments. IDMSIM™ Version 2.0 provides full MIL-STD-188-220B and MIL-STD-47001B capabilities as well as TACFIRE Display Page support. The IDMSIM™ System replaces the IDM V303™ and IDM V304™ Line Replaceable Unit (LRU) with a paired COTS PC system and allows access to the IDM Operational Flight Program (OFP) through the avionics MIL-STD-1553B interface. The IDMSIM™ system connects to the Ethernet and processes all signal and radio PDUs.



IDMSIM™ allows users to gain the experience they need in executing specific real world missions.

Current Users

Currently, the Longbow Apache training system uses the IDMSIM™ for training and certification. This system utilizes the IDM OFP version 5.01 and is comprised of two rack-mounted PCs interconnected via an Ethernet data bus.

Benefit

With the use of IDMSIM™, IDM users are more prepared and confident in the IDM capabilities when executing their real world missions.

Key Features

Hardware

2 CiDesign® RS 2100 2U Rack Mounted Servers running LynxOS 3.1a on Pentium III/900 MHz Processors:

PC1

- 1 Excalibur® MIL-STD-1553 PCI Card
- 2 100Mbps Ethernet Cards
- 2 20GB Removable Hard Drives (Primary and Backup)
- 256MB RAM

PC2

- 2 100Mbps Ethernet Cards
- 2 20GB Removable Hard Drives (Primary and Backup)
- 256MB RAM

Software

IDM OFP 5.01 Baseline containing TACFIRE



Product Highlights

- Fully Programmable Card
- Two Channel Interface
- Incorporates IDM Technology™ into a PC
- Highly Mobile Solution

PCIDM™ V2

The need for data connectivity between and among highly mobile ground units is becoming increasingly more critical as more and more targeting and Intelligence Surveillance and Reconnaissance (ISR) information is extracted from multiple, but frequently, disparate sources. Innovative Concepts, Inc.'s PCIDM™ bridges the gap and delivers the data.

What is PCIDM™?

The PCIDM™ is an inexpensive two-channel tactical modem/router manufactured as a PC-Card. It provides an alternative in situations where the 4- and 6-channel IDM LRU Avionics device might be inappropriate and competitive offerings ineffective. Fully compatible with all software versions of the avionics IDM devices, the PCIDM™ allows users to incorporate complete IDM functionality into a personal computer via installation of a standard Type II PCMCIA card.

Using PCIDM™, any Windows® or Linux-based personal computer can be put to immediate and effective use to host training, flight-testing, or mission control functions. PCIDM™ is also useful for transmission/reception and routing of C2 messages and situation awareness data, flight-operations data, and fire control missions.

The PCIDM™ PC-Card is small and light weight, and when coupled with a voice-grade radio, is capable of sending digital data information to a variety of military assets.

PCIDM™ supports the USAF AFAPD, Boeing Apache AFAPD, TACFIRE, MTS, JVMF*, and IDL message protocols and is fully compatible with the Internet Protocol, and the MIL-STD-188-220B/C protocol. PCIDM™'s IP stack delivers interoperability between fire and maneuver nets and is functionally compatible with institutionalized network interfaces.

In addition, the PCIDM™ can be user-programmed for additional message applications. Virtually any point-to-point protocol set can be deployed to supply near-real time data connectivity for air-to-ground support using PCIDM™.



Software Tool Support

PCIDM™ products include extensive software tool support in the form of a Software Development Kit (SDK), which makes use and re-use of the product easy and natural. The SDK provides users with both an application development and application integration tool.

In addition to the SDK, Innovative Concepts, Inc. offers the AMPGUI™ as part of the PCIDM™ solution to assist users in configuring the PCIDM™ and sending messages effortlessly. AMPGUI is a graphical user interface that makes the sending and receiving of messages available right out of the box.

Cost Effectiveness and Operational Performance

The PCIDM™ has contributed significantly to the success of several high-level programs by supplying reliable, affordable, and integrated IDM connectivity. With the use of the PCIDM™, users can communicate with multiple assets at the same time on the same frequency eliminating the need to install multiple avionics devices. The resulting connectivity enables delivery of situational awareness data, via platform-based sensors of the type installed on ISR and attack envelopes.

PCIDM™ delivers the same functionality as an avionics LRU at a fraction of the cost in both dollars and weight.

Please see reverse for technical information.

www.innocom.com
8200 greensboro drive suite 700 mclean va 22102 sales@innoco.com 703.893.2007

Copyright © Innovative Concepts, Inc. All rights reserved.

IDM TECHNOLOGY™

Key Features

Specifications

The PCIDM™ includes all discrete signals required to directly interface to 2 radios, including:

- RT-1523E (SINGARS SIP and ASIP)
- PRC-117F
- PRC-113
- PSC-5
- ARC-201D
- KY-58
- Other custom radio interfaces

Radio Interface Modes

- NRZ (up to 16 Kbps)
- Packet Mode (SINGARS X.21 packet mode)
- ASK - Amplitude Shift Key - (up to 16 Kbps asynchronous)
- FSK: Frequency Shift Key (up to 2400 bps)

Supported Protocols

- AFAPD
- TACFIRE
- MTS
- IDL
- MIL-STD-188-220B/C
- TCP/IP (IP, UDP, TCP, ICMP, ICMP+, IGMP, IGMP+, SNMP, RFC-1256+)

Messages

- AFAPD F-16
- AFAPD Apache
- Joint Variable Message Format (JVMF)*
- MTS
- IDL
- TACFIRE

Application Software available from Innovative Concepts, Inc.

- AMP@GUI - This application message parser supports all the message sets included with the PC-Card.
- MilX™ PTS is a precision targeting software application used by NATO Forward Air Controllers and fully integrated for use with IDM Technology™ products.
- The PCIDM™ Software Development Kit (SDK) allows custom application development and the integration of existing applications for use with the data communications features of PCIDM™.

Specifications

Attribute	PCIDM™ V2.6 - Domestic	PCIDM™ V2.6 - Export
Available	NOW	NOW
Channels	2	2
Link Layer Protocols	AFAPD TACFIRE MIL-STD-188-220B MTS IDL	AFAPD TACFIRE MIL-STD-188-220B MTS IDL MIL-STD-188-184
Network Layer Protocols	TCP/IP (IP, UDP, TCP, ICMP, ICMP+, IGMP, IGMP+, SNMP, RFC-1256+)	TCP/IP (IP, UDP, TCP, ICMP, IGMP, SNMP)
Application Message Sets	AFAPD F-16 AFAPD Apache JVMF* (Full) TACFIRE (limited) MTS (limited) IDL (full)	AFAPD F-16 AFAPD Apache JVMF* (Full) TACFIRE (limited) MTS (limited) IDL (full)
MIL-STD-188-220 Compatibility Tested	Fire Support AFATDS – TCIM Tactical Internet FBCB2 – INC	Internet
Radio Interfaces	PCIDM™ V2.6 - Domestic	PCIDM™ V2.6 - Export
NRZ (SDM)	2 Channels	2 Channels
Packet (X.21)	2 Channels	Not available
ASK	1 Channel	1 Channel
FSK	1 Channel	1 Channel
Hardware	PCIDM™ V2.6 - Domestic	PCIDM™ V2.6 - Export
Processors	1 PowerPC (40MHz) 1 DSP	1 PowerPC (40MHz) 1 DSP
Memory	32 MB SDRAM 16 MB FLASH 2 KB SEEPROM	32 MB SDRAM 16 MB FLASH 2 KB SEEPROM
Size	PCMCIA Type II Ext. PC-Card 54mm W 135mm D 5mm – 10 mm H	PCMCIA Type II Ext. PC-Card 54mm W 135mm D 5mm – 10 mm H
Power	Est. +5 V, 0.4 A, 2 W	Est. +5 V, 0.4 A, 2 W
Weight	5 ounces (w/ pigtail)	5 ounces (w/ pigtail)
Temperature	-40 to 85 c	-40 to 85 c
Functional Distribution	PCIDM™ V2.6 - Domestic	PCIDM™ V2.6 - Export
Physical Layer	Card	Card
Link Layer	Card	Card
Network Layer	Card	Card
Application Layer	Host	Host
Host Support	PCIDM™ V2.6 - Domestic	PCIDM™ V2.6 - Export
Device Drivers	Windows 98 Windows NT Windows 2000 Windows ME Windows XP Linux	Windows 98 Windows NT Windows 2000 Windows ME Windows XP Linux

*Subject to U.S. Government Approval.



Product Highlights

- Hostless Solution
- Two Channel Interface
- Ideal for Passing Data via Handheld Device
- Fully Programmable Card

BlueTAC™ Tactical Router

As do all IDM Technology™ products, BlueTAC™ offers a low cost solution for communicating in RF-based tactical networks. Unlike its stable mates, however, BlueTAC™ is host-less. It requires no additional hardware such as a mission computer. It also adds a wireless interface not presently available on other IDM Technology™ products, Bluetooth™.

What is BlueTAC™?

The BlueTAC™ card is both a network router and a gateway between Bluetooth™ wireless networks, Ethernet, and tactical radios. Being a member of the IDM Technology™ family assures interoperability of BlueTAC™ with all other products in the IDM Technology™ line. BlueTAC™ provides the potential to deploy a data communications link for all operating components of the battlefield - aviation units, ground forces, and ship-borne systems, allowing them to communicate using one seamless solution.

BlueTAC™ software functionality is identical to that supported by IDM V304™ LRU and PCIDM™. The hardware has two half-duplex radio channels configurable to operate with any of the supported protocols. Presently BlueTAC™ supports USAF AFAPD, Boeing Apache AFAPD, TACFIRE, MTS, JVMF*, and IDL message protocols and is fully compatible with MIL-STD-188-220B and MIL-STD-188-184 (SATCOM). In addition, BlueTAC™ can be user-programmed for additional message applications.

Since it is fully compatible with the avionics IDM, the BlueTAC™ card can be used to pass near real-time data to and from airborne or ground platforms to support C2 and fire control missions such as:

- Position Reporting
- Suppression of Enemy Air Defense (SEAD)
- Close Air Support (CAS)
- Forward Air Control (FAC).

Applications

The BlueTAC™ router is tailor made for mobility at the individual level. For example, BlueTAC™ is currently used in the **U.S. Army's Land Warrior** program. As part of this program, BlueTAC™ is embedded into the Thales-built MBITR (PRC-148) Leader Radio Adapter (LRA) to provide IP-based data communications capabilities in a handheld device to today's soldier.

This card is an ideal solution for integration programs that incorporate a need for middle-ware for weight reduction, IP-based messaging, embedded communications, interoperability, multiple-protocol support, and scalability.

Benefits

- Low power requirements
- Low hardware cost
- Interoperable with existing AFAPD, TACFIRE, MTS, and MIL-STD-188-220 data links
- Lightweight, can run without an additional host. BlueTAC™ is an superb candidate for integration into an already overcrowded aircraft, into a UAV requiring minimal hardware, or into ground units needing to pass digital information without additional equipment weighing them down.

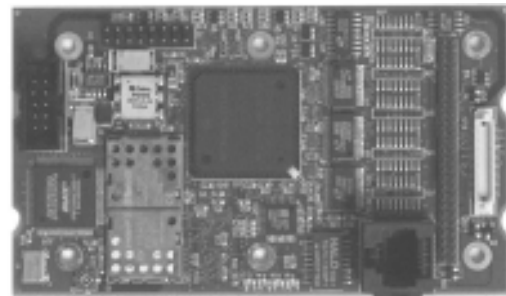

BlueTAC™ is an OEM offering that can be easily integrated into your solution.

Please see reverse for technical information.

www.innocon.com
8200 greensboro drive suite 700 mclean va 22102 sales@innocn.com 703.893.2007

IDM TECHNOLOGY™

Key Features

Specifications

The BlueTAC™ provides interface to 2 radios, including:

- SINGGARS SIP (ASIP) (RT-1523E)
- PRC-117
- PSC-5
- ARC-201D (Airborne SINGGARS SIP)
- KY-58
- Other Customer Radio Interfaces

Radio Interface Modes

- SDM: Synchronous Data Module (NRZ) (up to 16 kbps)
- X.21: packet mode

Supported Protocols

- AFAPD
- TACFIRE
- MIL-STD-188-220B
- TCP/IP (IP, UDP, TCP, ICMP, ICMP+, IGMP, IGMP+, SNMP, RFC-1256+)

Messages

- AFAPD F-16
- AFAPD Apache
- Joint Variable Message Format (JVMF)*
- TACFIRE
- IDL
- MTS

Specifications

Attribute	BlueTAC™ - Domestic	BlueTAC™ - Export
Available	NOW	NOW
Channels	2	
Link Layer Protocols	AFAPD TACFIRE MIL-STD-188-220B MTS IDL	AFAPD TACFIRE MIL-STD-188-220B MTS IDL
Network Layer Protocols	IP, ICMP, ICMP+, IGMP, IGMP+, SNMP, RFC-1256+...	IP, ICMP, IGMP, SNMP
Application Message Sets	AFAPD F-16 AFAPD Apache JVMF* (Full) TACFIRE (limited) MTS (limited) IDL (full)	AFAPD F-16 AFAPD Apache JVMF* (Full) TACFIRE (limited) MTS (limited) IDL (full)
MIL-STD-188-220B Compatibility Tested	Fire Support AFATDS – TCIM Tactical Internet FBCB2 – INC	IP, Private Nets
Radio Interfaces	BlueTAC™ - Domestic	BlueTAC™ - Export
NRZ (SDM)	2 Channels	2 Channels
Packet (X.21)	2 Channels	Not available
Hardware	BlueTAC™ - Domestic	BlueTAC™ - Export
Processors	1 PowerPC (40MHz)	1 PowerPC (40MHz)
Memory	32 MB SDRAM 16 MB FLASH 2 KB SEEPROM	32 MB SDRAM 16 MB FLASH 2 KB SEEPROM
Size	4.40"L 2.55"W 0.46" - .077"H	4.40"L 2.55"W 0.46" - .077"H
Power	Est. +5 V, 0.4 A, 2 W	Est. +5 V, 0.4 A, 2 W
Weight	5 ounces	5 ounces
Temperature	-40 to 85 c	-40 to 85 c
Functional Distribution	BlueTAC™ - Domestic	BlueTAC™ - Export
Physical Layer	Card	Card
Link Layer	Card	Card
Network Layer	Card	Card
Application Layer	Host	Host
Host Support	BlueTAC™ - Domestic	BlueTAC™ - Export
Host Interface	PPP Bluetooth™	PPP Bluetooth™
Ethernet	10 Base-T	10 Base-T
Bluetooth™	Version 1.1	Version 1.1

*Subject to U.S. Government Approval.



Product Highlights

- Precision Targeting System
- Ideal for Close Air Support Missions
- GPS, Laser Range Finder, and Data Communications Integrator

MilX™ Precision Targeting System (PTS)

What is MilX™ PTS?

MilX™ PTS is an operational precision targeting system used to send precise target information to aircraft in a CAS 9-Line format using IDM Technology™.



Capabilities

Forward Air Controllers (FACs) from several NATO nations have operationally fielded MilX™ PTS. It currently supports Operation Enduring Freedom. It is a fully integrated system with a range of capabilities such as:

- Real-time Targeting
- Digital Messaging
- GPS Navigation
- Route Planning
- Waypoint Folders
- Target Files

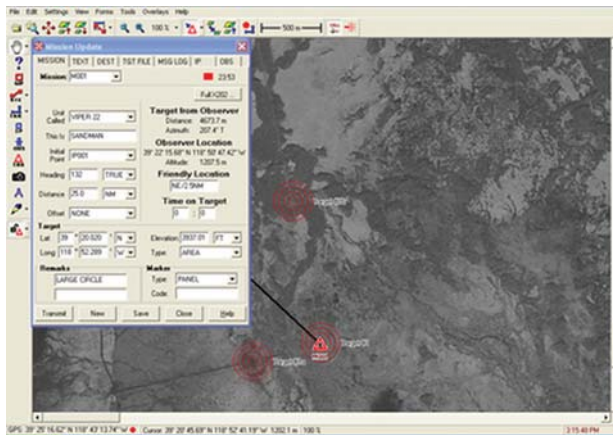

Real-Time Targeting

Benefits

- MilX™ PTS reduces the ground FACs workload by 40%
- MilX™ PTS reduces the cockpit workload by 80%
- Accuracy of <20 meters

Current Users

NATO Forces

Please see reverse for further MilX™ PTS information.

Key Features

Laser Integrations*

- Litton Mk VII
- OIP Gynometer
- Lica Vector 40

Protocols*

- AFAPD
- TACFIRE
- TCP/IP
- MIL-STD-188-220B
- JVMF

Radios*

- PRC-113
- PRC-117 D/F
- PSC-5

Map Protocols*

- NIMA CADRG-CIB
- BSB/Maptech/Softchart
- DRG/ChartTiff/JPR
- Fugawi Export
- GMF Vector Maps

*Not restricted to this list.

IDM TECHNOLOGY™

How Does MiIX™ PTS Work?

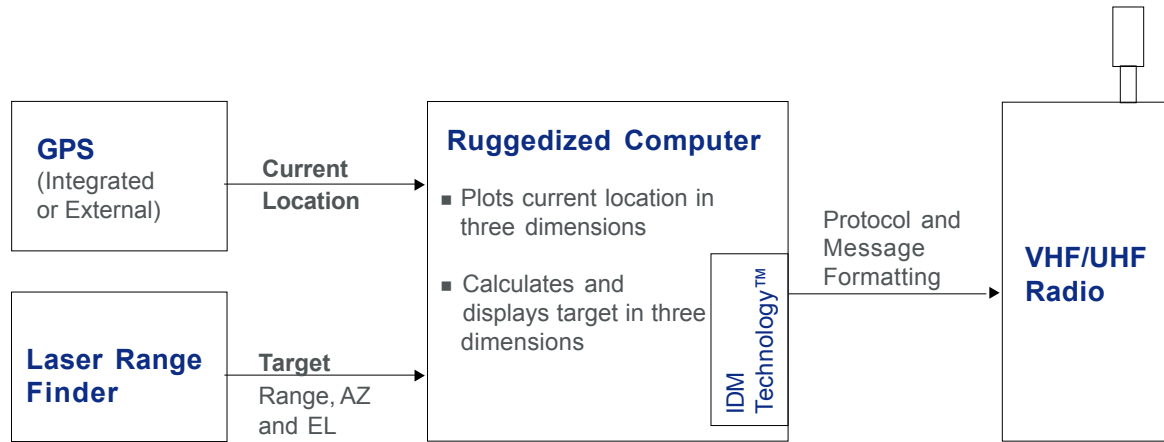

- MiIX™ PTS receives the observer's position from the GPS (in three dimensions) and displays the position on the selected map.
- When a target is lased, the range, azimuth, and elevation data from the laser range finder are transferred to the computer.
- The software then automatically calculates the offset and displays the target location on the map.
- A pull-down menu accesses the desired targeting message which is populated with the stored data.
- The remaining data fields are filled either by pull-down menus or data entry.
- The message is stored in the target file for either immediate or later transmission.
- When the message is transmitted, IDM Technology™ converts it to the selected protocol and initiates the radio transmission.

Real-Time Targeting

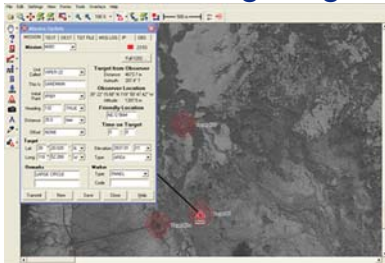

Digital Messaging

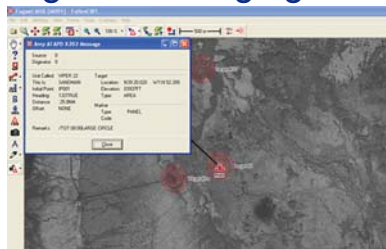

GPS Navigation

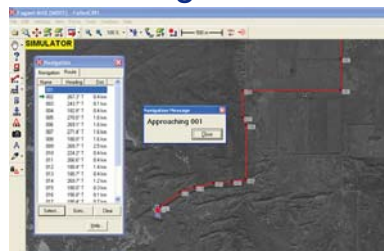

Route Planning



Waypoint Folders

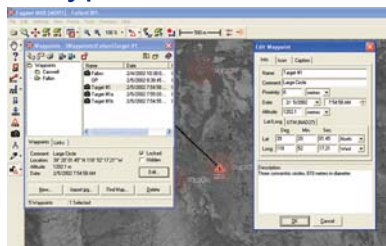





Target Files





Product Comparison

IDM Technology™

IDM Technology™ Product	Description	Supported Protocols	Radio Interfaces	Platform Host Interfaces	Sample of Current Users
IDM V304™ 	<ul style="list-style-type: none"> Lightweight Tactical Modem 6 Channel Interface Provides Digital Data Connectivity Memory Expansion Capabilities 	<ul style="list-style-type: none"> AFAPD TACFIRE MIL-STD 188-220 JVMF¹ EPLRS (X.25) Blue Force Tracking 	<ul style="list-style-type: none"> 4 Combat Net Radio (CNR) for analog or digital interfaces 1 HF/BlueForce Tracking 1 EPLRS Interface 	<ul style="list-style-type: none"> MIL-STD 1553B Ethernet 	<ul style="list-style-type: none"> F16 Apache Kiowa Black Hawk EA6B
IDMSIM™ 	<ul style="list-style-type: none"> Simulator Environment for IDM Technology™ Users Provides Real-time Training Environment Ensures Units are Prepared for Critical Missions 	<ul style="list-style-type: none"> AFAPD TACFIRE MIL-STD 188-220 JVMF¹ 	<ul style="list-style-type: none"> 4 Virtual CNR Radio Interfaces 	<ul style="list-style-type: none"> Ethernet 	<ul style="list-style-type: none"> Apache Longbow Training System
SCIDM™ 	<ul style="list-style-type: none"> PCI Mezzanine Card 2 Channel Interface Ideal for VME Based Mission Computers Minimizes Space, Weight and Power Requirements 	<ul style="list-style-type: none"> AFAPD TACFIRE MIL-STD 188-220 JVMF¹ Blue Force Tracking Intra-Flight Data Link (IDL) MTS 	<ul style="list-style-type: none"> 2 Digital Radio Interfaces or 1 Digital and 1 Analog Interface 	<ul style="list-style-type: none"> VME based mission computers 	Programmed for installation: <ul style="list-style-type: none"> British GR-7 Harrier Eurofighter Typhoon
PCIDM™ 	<ul style="list-style-type: none"> Fully Programmable Card 2 Channel Interface Incorporates IDM Technology™ into a PC Highly Mobile Solution 	<ul style="list-style-type: none"> AFAPD TACFIRE MIL-STD 188-220 JVMF¹ Intra-Flight Data Link (IDL) MTS 	<ul style="list-style-type: none"> 2 Digital Radio Interfaces or 1 Digital and 1 Analog Interface 	<ul style="list-style-type: none"> PCMCIA 	<ul style="list-style-type: none"> JSTARS Embedded in Ruggedized Handheld Computer (RHC)
BlueTAC™ 	<ul style="list-style-type: none"> Hostless Solution 2 Channel Interface Ideal for Passing Data via Handheld Device Fully Programmable Card 	<ul style="list-style-type: none"> AFAPD TACFIRE MIL-STD 188-220 JVMF¹ Intra-Flight Data Link (IDL) MTS 	<ul style="list-style-type: none"> 2 Digital Radio Interfaces 	<ul style="list-style-type: none"> Ethernet Bluetooth Serial Port (PPP) 	<ul style="list-style-type: none"> Land Warrior Leader Radio

Integration Support for IDM Technology™



Innovative Concepts, Inc. offers comprehensive solutions to address the unique challenges our customers face. We are dedicated to meeting your complex needs with engineering services that span key technology areas. We are customer driven, customizing our services to meet your specific requirements.

Innovative Concepts, Inc. will staff your project with highly skilled and motivated engineers who are teamed with an equally skilled and experienced program management organization, serving as your advocate and champion from program initiation through final delivery. This winning combination assures your successful product development effort.

Our team of engineers will work with you from start to finish to integrate IDM Technology™ quickly and effectively into your product, ensuring that it meets all technical and operational requirements. We offer the following engineering services in support of IDM Technology™:

Software Engineering

- Wireless Communications
- Tactical Data Links
- Communications Protocols
- Real-Time Embedded Systems
- Real-Time Networking
- Software-Based Solutions
- Digital Signal Processing
- Communications Protocols
- Automated Test Equipment
- Protocol Simulation
- Custom Graphical User Interfaces
- LynxOS, Solaris, Linux
- Windows 98/NT/2000/XP
- Windows CE/ Pocket PC 2000

Systems Engineering

- Communications Networks
- Digital Signal Processing
- Software-Based Solutions
- System Design and Simulation
- Hardware and Software Conceptual Design
- Requirements Definition
- SEI CMMI
- ISO 9001

Hardware Development

- System Design, Development and Manufacturing
- Communications Terminals
- Protocol Simulators
- Communication Link Simulators
- Automated Test Equipment
- FPGA/ASIC Development
- Parallel Processing
- Image Processing
- Processor Design
- Digital Signal Processing
- Custom Hardware Design to Military Specifications

www.innocon.com



Contract Vehicles



Access to our products and services is very straightforward with the use of our various contract vehicles. We make the process of doing business quick and seamless. Read on to learn about our contract vehicles.

GSA Professional Engineering Services Contract Number GS-23F-0204M







We offer a full range of engineering products and services including, strategic planning; concept development and requirements analysis; system design, engineering and integration; test and evaluation; integrated logistics support; and acquisition and lifecycle management via the GSA Schedule. The geographic scope of this contract is world-wide. In addition, the IDM V304™ is available on the schedule. For more information about our products and services, labor categories and rates, and ordering information, email us at sales@innococon.com to obtain a copy of our schedule, or visit GSA at www.gsa.gov.

CECOM Rapid Response (CR2) Program

Innovative Concepts, Inc. provides the U.S. Department of Defense and other government communities with immediate support for critical systems through the CR2 contract. Through the CR2, the contracting process will include a rapid turnaround time with minimal paperwork. For more information, email sales@innococon.com or visit CECOM's website at <https://r2csr.monmouth.army.mil/main.html>.

International Agents

Innovative Concepts, Inc. maintains a partnership with the following international agents. If you are located in one of the following countries, please contact your designated country IDM Technology™ representative for additional information.

Country	Company	Telephone	Email
 Australia	Owen International Pty Ltd	+61 (2) 9438 3477	owenint@ozemail.com.au
 Denmark	Hamann Electronics A/S	+45 59 46 86 14	kph@hamann.dk
 Israel	Sigmathek	+972 (3) 575 5704	zvi@sigmatek.co.il
 Japan	Global Electronics Corporation	+81 (3) 3260 1411	ishibashi@gec-tokyo.co.jp
 Korea	Dong Ryung Mulsan Company Ltd.	+82 (2) 701 9562	drmscl@hotmail.com
 Norway	Bedriftssystemer A/S	+47 (23) 40 03 25	steinar.eriksen@bedriftssystemer.no
 Poland	Dr. J. Rayski	+48-603-617-246	jrayski@pro.onet.pl
 Taiwan	Trivet Industrial Corp	886 (2) 2658-5152	jonesyen@tradeint.com.tw
 Turkey	S4T Ltd	90 216 545 04 48 90 312 441 52 40	abdalan.s4t@turk.net
 United Kingdom	General Dynamics UK Ltd.	+44 (0) 1424 853481	sales@generaldynamics.uk.com

Purchase Orders

We provide our customers with the option to purchase products and services directly from us via a purchase order. If you are interested in doing so, email sales@innococon.com to discuss your purchasing needs and to obtain a quote.

Credit Card Acceptance

For your convenience, Innovative Concepts, Inc. accepts Visa and MasterCard as means of payment. Please email us at sales@innococon.com to discuss your purchasing needs.

www.innococon.com

